



0,00		5	Afer
------	---	---	------

PIZZARIA BLACK BURGER

1,31		6	Afer
------	---	---	------



Início de Prova
ZERE NA ÁRVORE

	ATENÇÃO
	CUIDADO
	PERIGO

Tempo de Prova

MAS / SEN	06:12:03
JUN / OVR	06:20:21
NOV / TUR	06:37:50



AFERIÇÃO
PIZZARIA BLACK BURGER

0,00		1	F	Afer
Q.M.				

0,06		2	Afer
------	---	---	------

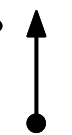
0,55		3	Afer
------	---	---	------

AFERIR NO QUEBRA MOLA COM 1.310 KM

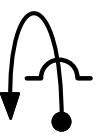
1,31		4	Afer
------	---	---	------

0,00		5	Afer
------	---	---	------

PIZZARIA BLACK BURGER

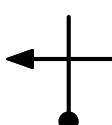
1,31		6	Afer
------	---	---	------



Início de Prova
ZERE NA ÁRVORE

Deslocamento

0,00		7	D	D1	5'	0.00.00
					5'	0.00.00
					5'	0.00.00

0,06		8	D1
------	---	---	----

0,55		9	D1
------	---	---	----

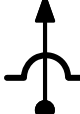
0,62		10	D1
------	---	----	----

0,93		11	D1
------	---	----	----

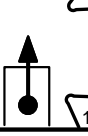
1,24		12	D1
------	---	----	----

0,00		12	V	V2	0.05.00	0.05.00	0.05.00
------	---	----	---	----	---------	---------	---------

NO BURACO

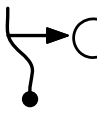
0,06		13	V2	0.05.18	0.05.18	0.05.18
------	---	----	----	---------	---------	---------

GAZZZ

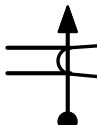
0,08		14	V2	0.05.24	0.05.24	0.05.24
------	---	----	----	---------	---------	---------

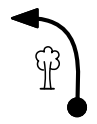
0,11		15	V2	0.05.33	0.05.33	0.05.33
------	---	----	----	---------	---------	---------

BANDEIRAS

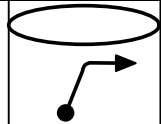
0,15		16	V2	0.05.45	0.05.45	0.05.45
------	---	----	----	---------	---------	---------

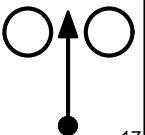
0,22		17	V2	0.06.06	0.06.06	0.06.06
------	---	----	----	---------	---------	---------

GAZZZ TOCO

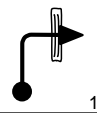
0,33		18	V2	0.06.39	0.06.39	0.06.39
------	---	----	----	---------	---------	---------

0,35		19	V2	0.06.45	0.06.45	0.06.45
------	---	----	----	---------	---------	---------

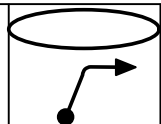
0,44		20	V2	0.07.12	0.07.12	0.07.12
------	---	----	----	---------	---------	---------



0,54		21	V2	0.07.42	0.07.42	0.07.42
------	---	----	----	---------	---------	---------

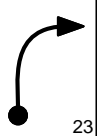

CURVA DE NIVEL

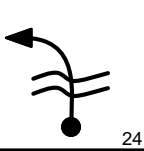
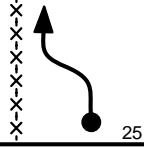
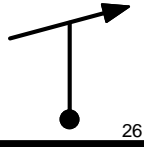
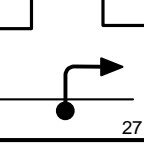
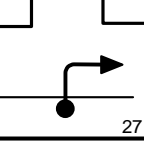
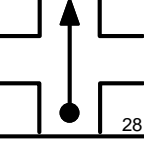
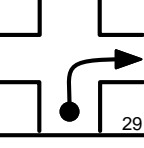
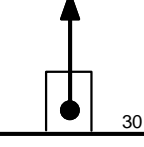
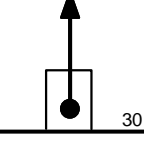
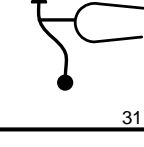
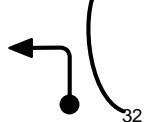
0,62		22	V2	0.08.06	0.08.06	0.08.06
------	---	----	----	---------	---------	---------

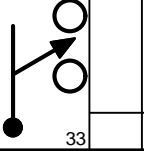
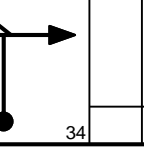
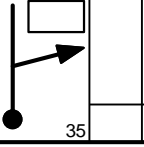
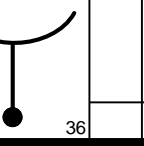
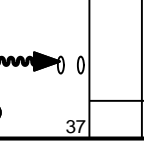
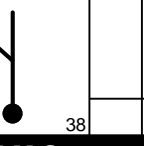
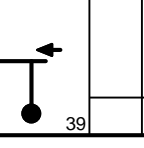
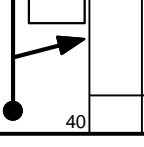
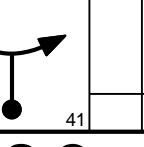
0,68		23	V2	0.08.24	0.08.24	0.08.24
------	---	----	----	---------	---------	---------

TRILHAS DO ALEMÃO		4/60	
CURVA DE NIVEL			
0,74		0.08.42 0.08.42 0.08.42	V2
0,81		0.09.03 0.09.03 0.09.03	V2
0,91		0.09.33 0.09.33 0.09.33	V2
Deslocamento			
1,00		0.10.00 0.10.00 0.10.00	V2
0,00		3' 0.10.00 3' 0.10.00 3' 0.10.00	D D3
0,07			D3
0,37			D3
0,41			D3
0,00		12 0.13.00 12 0.13.00 12 0.13.00	V V4
0,06		0.13.18 0.13.18 0.13.18	V4
0,10		0.13.30 0.13.30 0.13.30	V4

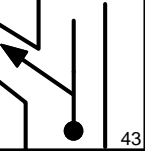
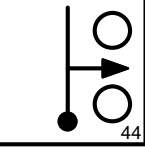
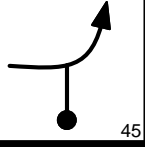
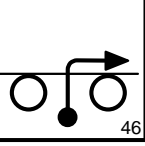
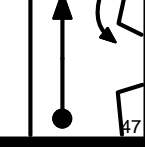
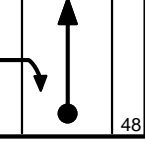
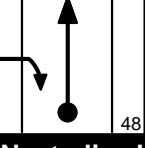
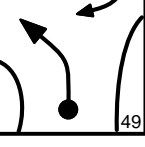
TRILHAS DO ALEMÃO		5/60	
0,37		0.14.51 0.14.51 0.14.51	V4
0,41		0.15.03 0.15.03 0.15.03	V4
0,52		0.15.36 0.15.36 0.15.36	V4
0,62		0.16.06 0.16.06 0.16.06	V4
GÁZZZZ PNEUS			
0,72		0.16.36 0.16.36 0.16.36	V4
0,76		0.16.48 0.16.48 0.16.48	V4
M.M.S.			
0,85		0.17.15 0.17.15 0.17.15	V4
0,97		0.17.51 0.17.51 0.17.51	V4
1,06		0.18.18 0.18.18 0.18.18	V4
M.S.C.			
Deslocamento			
1,09		2' 0.18.27 2' 0.18.27 2' 0.18.27	D D5

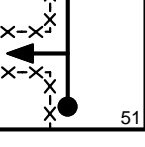
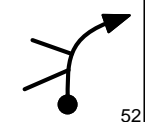
TRILHAS DO ALEMÃO		6/60	
1,19			D5
1,28		12 0.20.27 12 0.20.27 12 0.20.27	V V6
1,32		0.20.39 0.20.39 0.20.39	V6
Deslocamento			
1,42		2' 0.21.09 2' 0.21.09 2' 0.21.09	D D7
1,53			D7
NO POSTE			
1,63			D7
0,00		36 0.23.09 33 0.23.09 30 0.23.09	V V8
Neutralizado			
0,08		5' 0.23.17 4' 0.23.18 3' 0.23.19	N N9
0,08		39 0.28.17 36 0.27.18 33 0.26.19	V V10
0,76		0.29.20 0.28.26 0.27.33	V10
0,89		0.29.32 0.28.39 0.27.47	V10

TRILHAS DO ALEMÃO		7/60
1,02		0.29.44 0.28.52 0.28.01 V10
1,10		0.29.51 0.29.00 0.28.10 V10
1,78		0.30.54 0.30.08 0.29.24 V10
2,00		0.31.14 0.30.30 0.29.48 V10
2,19		0.31.32 0.30.49 0.30.09 V10
2,78		0.32.26 0.31.48 0.31.13 V10
2,87		0.32.35 0.31.57 0.31.23 V10
3,11		0.32.57 0.32.21 0.31.49 V10
3,15		0.33.00 0.32.25 0.31.54 V10
3,23		0.33.08 0.32.33 0.32.02 V10
CDD!!! RODOVIA		
3,38		0.33.22 0.32.48 0.32.19 V10









TRILHAS DO ALEMÃO		8/60
3,47		0.33.30 0.32.57 0.32.28 V10
3,56		0.33.38 0.33.06 0.32.38 V10
3,60		0.33.42 0.33.10 0.32.43 V10
3,94		0.34.13 0.33.44 0.33.20 V10
4,01		0.34.20 0.33.51 0.33.27 V10
4,03		0.34.22 0.33.53 0.33.30 V10
4,11		0.34.29 0.34.01 0.33.38 V10
CDD!!! RODOVIA		
4,25		0.34.42 0.34.15 0.33.54 V10
4,34		0.34.50 0.34.24 0.34.03 V10
4,56		0.35.11 0.34.46 0.34.27 V10
4,64		0.35.18 0.34.54 0.34.36 V10





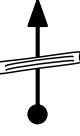
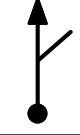

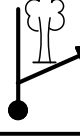
TRILHAS DO ALEMÃO		9/60
4,78		0.35.31 0.35.08 0.34.51 V10
4,87		0.35.39 0.35.17 0.35.01 V10
4,96		0.35.47 0.35.26 0.35.11 V10
5,01		0.35.52 0.35.31 0.35.16 V10
5,35		0.36.23 0.36.05 0.35.54 V10
5,63		0.36.49 0.36.33 0.36.24 V10
0,00		39 0.36.49 36 0.36.33 33 0.36.24 V V11
0,41		0.37.27 0.37.14 0.37.09 V11
1,08		0.38.29 0.38.21 0.38.22 V11
1,76		0.39.32 0.39.29 0.39.36 V11
1,88		0.39.43 0.39.41 0.39.49 V11

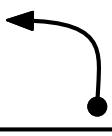
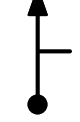

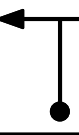
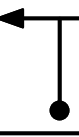
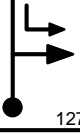
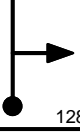
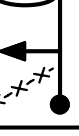
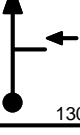

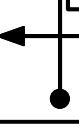

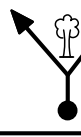

TRILHAS DO ALEMÃO		10/60
2,01		0.39.55 0.39.54 0.40.03 V11
2,10		0.40.03 0.40.03 0.40.13 V11
2,22		0.40.14 0.40.15 0.40.26 V11
ÁRVORE CAÍDA		
2,40		0.40.31 0.40.33 0.40.46 V11
2,91		0.41.18 0.41.24 0.41.42 V11
RUMO AO ECALIPTO		
3,07		18 0.41.33 15 0.41.40 12 0.41.59 V V12
MMS		
3,15		0.41.49 0.41.59 0.42.23 V12
CDD!!! REPRESA		
3,24		0.42.07 0.42.21 0.42.50 V12
3,36		0.42.31 0.42.49 0.43.26 V12
3,46		0.42.51 0.43.13 0.43.56 V12
3,56		0.43.11 0.43.37 0.44.26 V12

TRILHAS DO ALEMÃO		11/60
FORA DA CANALETA		
3,61		0.43.21 0.43.49 0.44.41 V12
3,71		0.43.41 0.44.13 0.45.11 V12
3,79		0.43.57 0.44.33 0.45.35 V12
3,91		0.44.21 0.45.01 0.46.11 V12
Neutralizado		
4,16		2' 0.45.11 1' 0.46.01 1' 0.47.26 N N13
0,00		45 0.47.11 42 0.47.01 39 0.48.26 V V14
0,87		0.48.20 0.48.16 0.49.46 V14
1,24		0.48.50 0.48.48 0.50.20 V14
1,54		0.49.14 0.49.13 0.50.48 V14
2,10		0.49.59 0.50.01 0.51.40 V14
ARVORE CAIDA		
2,26		0.50.11 0.50.15 0.51.55 V14

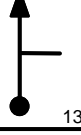
TRILHAS DO ALEMÃO		12/60
2,78		0.50.53 0.51.00 0.52.43 V14
2,90		0.51.03 0.51.10 0.52.54 V14
ATENÇÃO RODOVIA!!!		
Deslocamento		
3,04		1' 0.51.14 1' 0.51.22 1' 0.53.07 D D15
CDD!!! AO ATRAVESSAR A RODOVIA		
Deslocamento		
3,10		0.52.14 0.52.22 0.54.07 D15
0,00		1' 0.52.14 1' 0.52.22 1' 0.54.07 D D16
0,54		45 0.53.14 42 0.53.22 39 0.55.07 V V17
1,48		0.54.29 0.54.42 0.56.33 V17
2,18		15 0.55.25 12 0.55.42 9 0.57.38 V V18
TRONCO		
2,38		0.56.13 0.56.42 0.58.58 V18

TRILHAS DO ALEMÃO		13/60	
2,47		18 15 12 V	0.56.35 0.57.09 0.59.34 V19
2,53		116	0.56.47 0.57.24 0.59.52 V19
2,92		117	0.58.05 0.58.57 1.01.49 V19
3,25		15 12 9 V	0.59.11 1.00.17 1.03.28 V20
CDD!!! CHIFRE			
4,06		119	1.02.25 1.04.20 1.08.52 V20
4,24		120	1.03.08 1.05.14 1.10.04 V20
4,25		36 33 30 V	1.03.11 1.05.17 1.10.08 V21
AMEIXA			
4,57		18 15 12 V	1.03.43 1.05.52 1.10.46 V22
4,60		36 33 30 V	1.03.49 1.05.59 1.10.55 V23
4,87		124	1.04.16 1.06.28 1.11.28 V23
4,99		45 42 39 V	1.04.28 1.06.41 1.11.42 V24

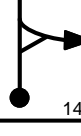

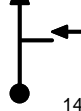



TRILHAS DO ALEMÃO		14/60	
5,58		45 42 39 V	1.05.15 1.07.32 1.12.37 V24
0,00		45 42 39 V	1.05.15 1.07.32 1.12.37 V25
0,52		127	1.05.56 1.08.16 1.13.25 V25
1,50		128	1.07.15 1.09.40 1.14.55 V25
1,78		15 12 12 V	1.07.37 1.10.04 1.15.21 V26
1,80		130	1.07.42 1.10.10 1.15.27 V26
1,87		131	1.07.59 1.10.31 1.15.48 V26
1,95		132	1.08.18 1.10.55 1.16.12 V26
2,05		133	1.08.42 1.11.25 1.16.42 V26
2,09		134	1.08.52 1.11.37 1.16.54 V26
2,18		135	1.09.13 1.12.04 1.17.21 V26



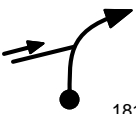
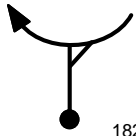

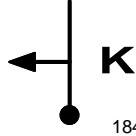
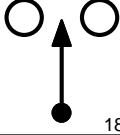
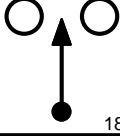
TRILHAS DO ALEMÃO		15/60	
2,29		136	1.09.40 1.12.37 1.17.54 V26
2,36		137	1.09.56 1.12.58 1.18.15 V26
2,72		138	1.11.23 1.14.46 1.20.03 V26
2,76		139	1.11.32 1.14.58 1.20.15 V26
2,78		140	1.11.37 1.15.04 1.20.21 V26
Neutralizado			
2,84		141	2' 1.11.52 1' 1.15.22 1' 1.20.39 N N27
0,00		45 42 39 V	1.13.52 1.16.22 1.21.39 V28
0,35		143	1.14.20 1.16.52 1.22.11 V28
0,84		144	1.14.59 1.17.34 1.22.56 V28
1,46		18 15 12 V	1.15.48 1.18.28 1.23.54 V29
1,50		146	1.15.56 1.18.37 1.24.06 V29

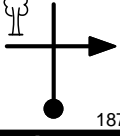
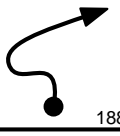
TRILHAS DO ALEMÃO		16/60
1,53		1.16.02 1.18.44 1.24.15 V29
ÁRVORE CAÍDA		
1,54		1.16.04 1.18.47 1.24.18 V29
1,59		1.16.14 1.18.59 1.24.33 V29
1,94		1.17.24 1.20.23 1.26.18 V29
1,97		1.17.30 1.20.30 1.26.27 V29
ÁRVORE CAÍDA		
1,98		1.17.32 1.20.32 1.26.30 V29
2,04		1.17.44 1.20.47 1.26.48 V29
2,18		1.18.12 1.21.20 1.27.30 V29
2,25		1.18.26 1.21.37 1.27.51 V29
2,71		1.19.58 1.23.28 1.30.09 V29
2,91		1.20.38 1.24.16 1.31.09 V29

TRILHAS DO ALEMÃO		17/60
3,08		1.21.12 1.24.56 1.32.00 V29
3,46		1.22.28 1.26.28 1.33.54 V29
4,13		36 1.24.42 33 1.29.08 30 1.37.15 V V30
4,52		1.25.21 1.29.51 1.38.01 V30
5,12		1.26.21 1.30.56 1.39.13 V30
Neutralizado		
5,65		3' 1.27.14 2' 1.31.54 1' 1.40.17 N N31
0,00	N	51 1.30.14 48 1.33.54 45 1.41.17 V V32
1,58		1.32.06 1.35.53 1.43.23 V32
2,43		1.33.06 1.36.56 1.44.31 V32
4,58		1.35.38 1.39.38 1.47.23 V32
5,63		1.36.52 1.40.56 1.48.47 V32

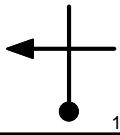
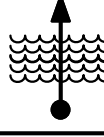
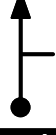
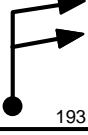
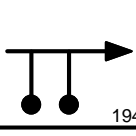

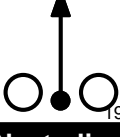
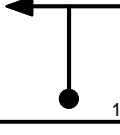

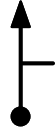

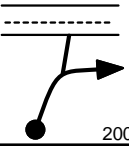
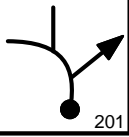
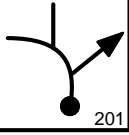
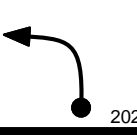
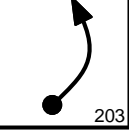
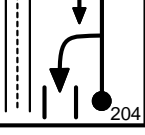
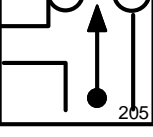
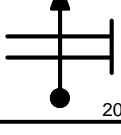
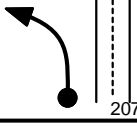
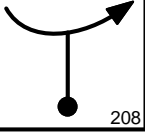
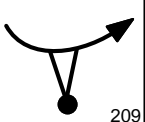
TRILHAS DO ALEMÃO		18/60
5,87		1.37.09 1.41.14 1.49.07 V32
7,11		1.38.36 1.42.47 1.50.46 V32
8,01		1.39.40 1.43.55 1.51.58 V32
8,35		1.40.04 1.44.20 1.52.25 V32
8,73		1.40.31 1.44.49 1.52.55 V32
8,81		1.40.36 1.44.55 1.53.02 V32
9,00		1.40.50 1.45.09 1.53.17 V32
9,58		1.41.31 1.45.53 1.54.03 V32
10,51		1.42.36 1.47.02 1.55.18 V32
11,24		1.43.28 1.47.57 1.56.16 V32
12,22		1.44.37 1.49.11 1.57.35 V32

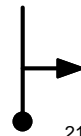
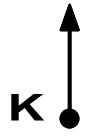
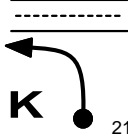
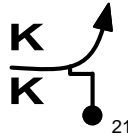
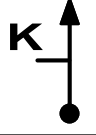
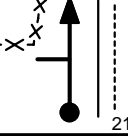
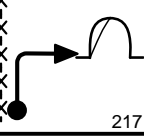
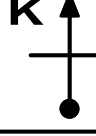
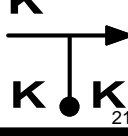
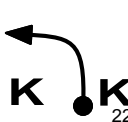

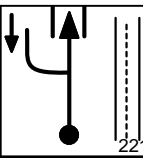
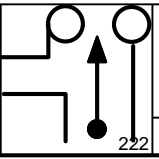
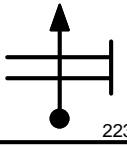
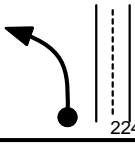
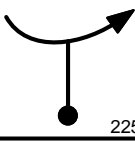
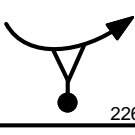

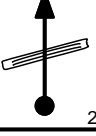

TRILHAS DO ALEMÃO		19/60	
12,49		1.44.56 1.49.31 1.57.56	V32
12,69		1.45.10 1.49.46 1.58.12	V32
13,04		1.45.35 1.50.12 1.58.40	V32
13,53		1.46.10 1.50.49 1.59.19	V32
13,87		1.46.34 1.51.14 1.59.47	V32
14,56		1.47.22 1.52.06 2.00.42	V32
0,00		12 1.47.22 12 1.52.06 12 2.00.42	V V33
0,04		1.47.34 1.52.18 2.00.54	V33
0,14		1.48.04 1.52.48 2.01.24	V33
GÁZZZZZ			
0,16		1.48.10 1.52.54 2.01.30	V33
0,20		1.48.22 1.53.06 2.01.42	V33

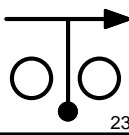

TRILHAS DO ALEMÃO		20/60	
0,34		1.49.04 1.53.48 2.02.24	V33
0,55		1.50.07 1.54.51 2.03.27	V33
0,80		1.51.22 1.56.06 2.04.42	V33
SUBA GÁZZZZZ			
0,81		1.51.25 1.56.09 2.04.45	V33
0,84		1.51.34 1.56.18 2.04.54	V33
0,85		1.51.37 1.56.21 2.04.57	V33
0,92		42 1.51.58 39 1.56.42 36 2.05.18	V V34
Neutralizado			
2,29		5' 1.53.56 3' 1.58.49 2' 2.07.35	N N35
			
0,00	N	42 1.58.56 39 2.01.49 36 2.09.35	V V36
0,10		1.59.04 2.01.58 2.09.45	V36

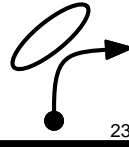
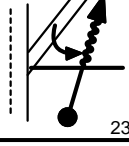
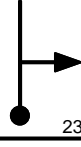
TRILHAS DO ALEMÃO		21/60	
2,07		2.01.53 2.05.00 2.13.02	V36
2,16		2.02.01 2.05.08 2.13.11	V36
0,00		24 2.02.01 21 2.05.08 18 2.13.11	V V37
0,08		2.02.13 2.05.22 2.13.27	V37
ÁRVORE CAÍDA			
0,31		2.02.47 2.06.01 2.14.13	V37
0,61		2.03.32 2.06.53 2.15.13	V37
0,80		2.04.01 2.07.25 2.15.51	V37
0,90		2.04.16 2.07.42 2.16.11	V37
1,05		2.04.38 2.08.08 2.16.41	V37
1,10		33 2.04.46 30 2.08.17 27 2.16.51	V V38
1,14		2.04.50 2.08.21 2.16.56	V38

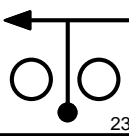
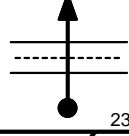

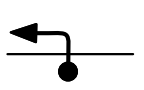
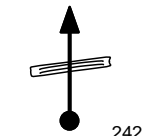
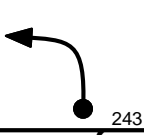

TRILHAS DO ALEMÃO		22/60
1,57		2.05.37 2.09.13 2.17.54 V38
1,63		2.05.44 2.09.20 2.18.02 V38
1,83		2.06.05 2.09.44 2.18.28 V38
1,92		2.06.15 2.09.55 2.18.40 V38
2,10		2.06.35 2.10.17 2.19.04 V38
2,19		2.06.45 2.10.27 2.19.16 V38
2,34		2.07.01 2.10.45 2.19.36 V38
TUNEL		
2,48		2.07.16 2.11.02 2.19.55 V38
2,65		2.07.35 2.11.23 2.20.18 V38
2,86		2.07.58 2.11.48 2.20.46 V38
MUITO CUIDADO		
2,88		2.08.00 2.11.50 2.20.48 V38

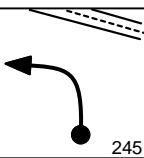
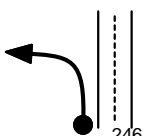
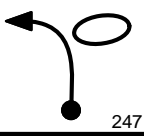
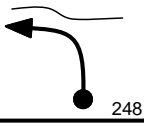
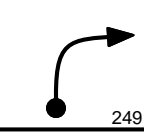
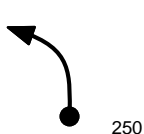

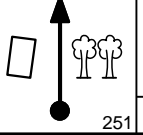
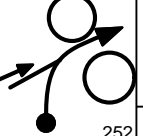
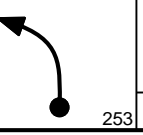
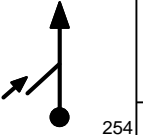
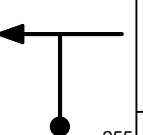
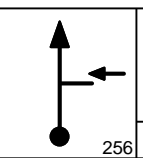
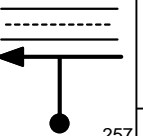
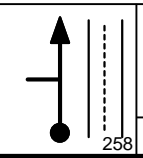
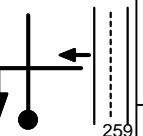
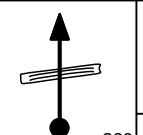
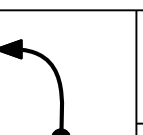

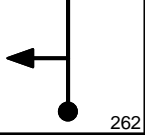

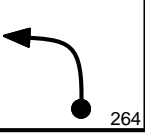
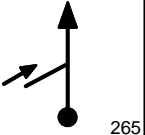
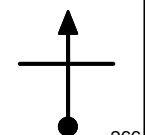
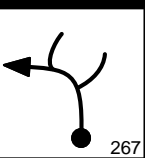
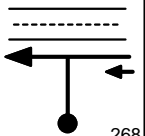
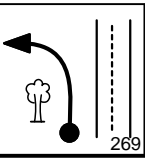
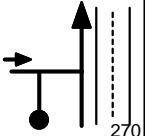

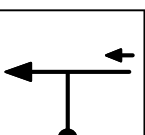
TRILHAS DO ALEMÃO		23/60
3,04		24 2.08.17 21 2.12.09 18 2.21.10 V V39
3,22		2.08.44 2.12.40 2.21.46 V39
3,32		2.08.59 2.12.57 2.22.06 V39
3,48		2.09.23 2.13.25 2.22.38 V39
3,52		33 2.09.29 30 2.13.32 27 2.22.46 V V40
3,57		2.09.35 2.13.38 2.22.52 V40
3,99		2.10.21 2.14.28 2.23.48 V40
4,05		2.10.27 2.14.35 2.23.56 V40
4,08		18 2.10.31 15 2.14.39 12 2.24.00 V V41
4,15		2.10.45 2.14.56 2.24.21 V41
4,17		2.10.49 2.15.00 2.24.27 V41

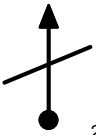
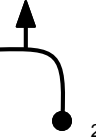

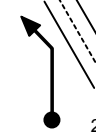
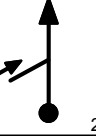

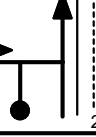
TRILHAS DO ALEMÃO		24/60
4,28		39 2.11.11 36 2.15.27 33 2.25.00 V V42
4,91		2.12.09 2.16.30 2.26.09 V42
5,73		2.13.24 2.17.52 2.27.38 V42
M.M.S.		
6,13		21 2.14.01 18 2.18.32 15 2.28.22 V V43
6,22		2.14.17 2.18.50 2.28.44 V43
6,73		2.15.44 2.20.32 2.30.46 V43
6,74		2.15.46 2.20.34 2.30.48 V43
CRUZE A RODOVIA E NEUTRALIZE DO OUTRO LADO		
Neutralizado		
6,85		5' 2.16.05 3' 2.20.56 2' 2.31.15 N N44
SUBA GÁZZZZZ, BANDEIRAS!!!		
0,00		15 2.21.05 12 2.23.56 12 2.33.15 V V45





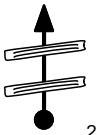
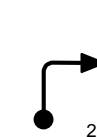

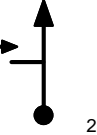
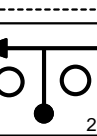
TRILHAS DO ALEMÃO		25/60
0,01		2.21.07 2.23.59 2.33.18 V45
TRONCO		
0,07		2.21.22 2.24.17 2.33.36 V45
0,14		2.21.38 2.24.38 2.33.57 V45
RUMO AS ÁRVORES E BANDEIRAS		
0,15		2.21.41 2.24.41 2.34.00 V45
0,33		2.22.24 2.25.35 2.34.54 V45
DESÇA		
0,40		2.22.41 2.25.56 2.35.15 V45
CDD!!! VALETA		
0,48		2.23.00 2.26.20 2.35.39 V45
CURVA DE NÍVEL		
0,54		2.23.14 2.26.38 2.35.57 V45
0,63		2.23.36 2.27.05 2.36.24 V45
0,65		2.23.41 2.27.11 2.36.30 V45

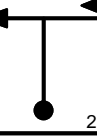
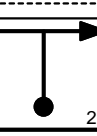
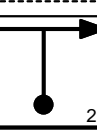
TRILHAS DO ALEMÃO		26/60
0,70		2.23.53 2.27.26 2.36.45 V45
0,75		2.24.05 2.27.41 2.37.00 V45
DESÇA		
0,79		2.24.14 2.27.53 2.37.12 V45
0,89		2.24.38 2.28.23 2.37.42 V45
0,95		2.24.53 2.28.41 2.38.00 V45
1,00		2.25.05 2.28.56 2.38.15 V45
1,01		2.25.07 2.28.59 2.38.18 V45
1,05		2.25.17 2.29.11 2.38.30 V45
SUBA GÁZZZZZ		
1,15		2.25.41 2.29.41 2.39.00 V45
TRONCO		
1,23		2.26.00 2.30.05 2.39.24 V45
1,31		2.26.19 2.30.29 2.39.48 V45

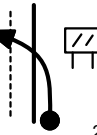

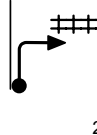
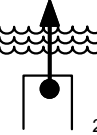
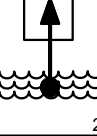
TRILHAS DO ALEMÃO		27/60
1,32		2.26.22 2.30.32 2.39.51 V45
1,35		2.26.29 2.30.41 2.40.00 V45
DESÇA		
1,40		2.26.41 2.30.56 2.40.15 V45
1,50		2.27.05 2.31.26 2.40.45 V45
1,56		2.27.19 2.31.44 2.41.03 V45
SUBA GÁZZZZZ		
1,65		2.27.41 2.32.11 2.41.30 V45
1,69		2.27.50 2.32.23 2.41.42 V45
1,74		2.28.02 2.32.38 2.41.57 V45
1,78		2.28.12 2.32.50 2.42.09 V45
SUBA GÁZZZZZ		
1,83		2.28.24 2.33.05 2.42.24 V45
1,92		2.28.46 2.33.32 2.42.51 V45

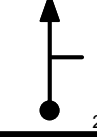
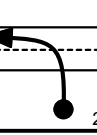
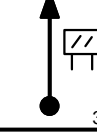
TRILHAS DO ALEMÃO		28/60
1,98		2.29.00 2.33.50 2.43.09 V45
SUBA GÁZZZZZ		
2,07		2.29.22 2.34.17 2.43.36 V45
2,14		2.29.38 2.34.38 2.43.57 V45
2,16		2.29.43 2.34.44 2.44.03 V45
2,19		2.29.50 2.34.53 2.44.12 V45
2,25		2.30.05 2.35.11 2.44.30 V45
2,29		2.30.14 2.35.23 2.44.42 V45
2,34		2.30.26 2.35.38 2.44.57 V45
2,43		2.30.48 2.36.05 2.45.24 V45
2,49		2.31.02 2.36.23 2.45.42 V45
2,58		2.31.24 2.36.50 2.46.09 V45

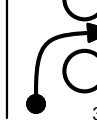
TRILHAS DO ALEMÃO		29/60
CHIFRES		
2,66		2.31.43 2.37.14 2.46.33 V45
2,72		2.31.58 2.37.32 2.46.51 V45
TRONCO		
2,77		2.32.10 2.37.47 2.47.06 V45
2,82		2.32.22 2.38.02 2.47.21 V45
2,90		2.32.41 2.38.26 2.47.45 V45
2,97		2.32.58 2.38.47 2.48.06 V45
3,00		2.33.05 2.38.56 2.48.15 V45
PELO ACOSTAMENTO!!!		
Deslocamento		
3,08		2.33.24 2.39.20 2.48.39 V45
0,00		3' 2.33.24 3' 2.39.20 3' 2.48.39 D D46
RUMO AO RETORNO		

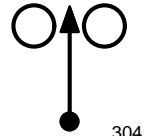
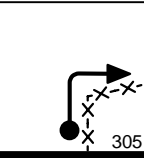
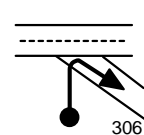
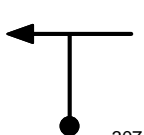
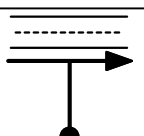
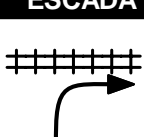
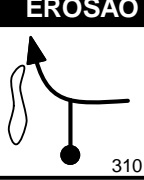
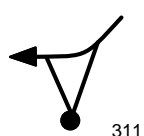
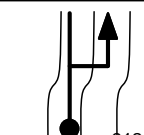
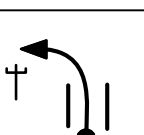
TRILHAS DO ALEMÃO		30/60
PLACA ROLÂNDIA		
0,16		292 D46
RETORNE		
0,23		293 D46
DESÇA		
0,25		12 2.36.24 12 2.42.20 12 2.51.39 V V47
0,27		2.36.30 2.42.26 2.51.45 V47
0,29		2.36.36 2.42.32 2.51.51 V47
0,40		2.37.09 2.43.05 2.52.24 V47
0,48		2.37.33 2.43.29 2.52.48 V47
Deslocamento		
0,55		2' 2.37.54 2' 2.43.50 2' 2.53.09 D D48
0,64		300 D48
0,94		301 D48
Neutralizado		
0,99		2' 2.39.54 1' 2.45.50 1' 2.55.09 N N49

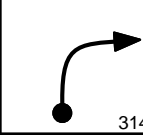
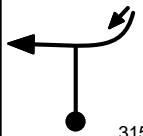
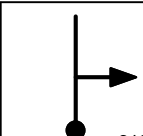
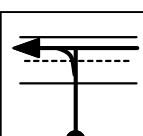
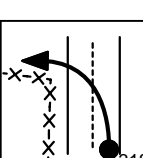
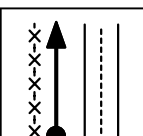
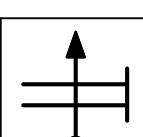
TRILHAS DO ALEMÃO		31/60	
0,00	N	18 15 12	2.41.54 2.46.50 2.56.09
		V	V50
0,12			2.42.18 2.47.19 2.56.45
			V50
0,19			2.42.32 2.47.35 2.57.06
			V50
NA CANALETA			
0,26			2.42.46 2.47.52 2.57.27
			V50
0,36			2.43.06 2.48.16 2.57.57
			V50
0,37			2.43.08 2.48.19 2.58.00
			V50
ESCADA			
0,40			2.43.14 2.48.26 2.58.09
			V50
EROSÃO			
0,44			2.43.22 2.48.35 2.58.21
			V50
0,46			2.43.26 2.48.40 2.58.27
			V50
ENTRE TUNEL DA DIREITA			
0,49			2.43.32 2.48.47 2.58.36
			V50
0,57			2.43.48 2.49.07 2.59.00
			V50

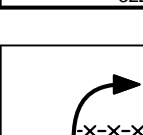
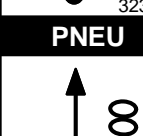
TRILHAS DO ALEMÃO		32/60	
0,61			2.43.56 2.49.16 2.59.12
			V50
0,67			2.44.08 2.49.31 2.59.30
			V50
0,73			2.44.20 2.49.45 2.59.48
			V50
0,95		33 30 27	2.45.04 2.50.38 3.00.54
		V	V51
1,26			2.45.38 2.51.15 3.01.35
			V51
1,41		18 15 12	2.45.54 2.51.33 3.01.55
		V	V52
1,54			2.46.20 2.52.04 3.02.34
			V52
FORA DA CANALETA			
1,64			2.46.40 2.52.28 3.03.04
			V52
DEÇA BEIRANDO			
1,73			2.46.58 2.52.50 3.03.31
			V52
1,89			2.47.30 2.53.28 3.04.19
			V52
PNEU			
1,90		8	2.47.32 2.53.31 3.04.22
			V52

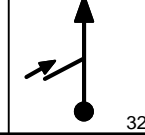
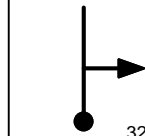
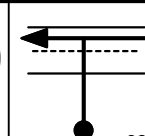
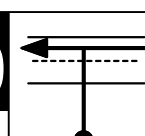
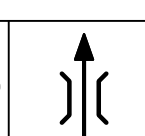
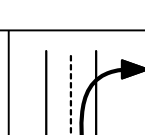
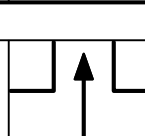
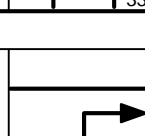
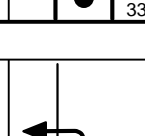
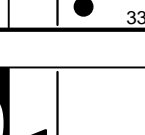
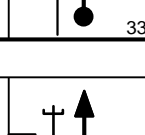
TRILHAS DO ALEMÃO		33/60	
2,02			2.47.56 2.53.59 3.04.58
			V52
2,09			2.48.10 2.54.16 3.05.19
			V52
Deslocamento			
2,30			2.48.52 2.55.07 3.06.22
			V52
0,00		10' 10' 10'	2.48.52 2.55.07 3.06.22
		D	D53
0,36			
			D53
1,73			
			D53
1,85			
			D53
2,11			
			D53
2,12			
			D53
0,00		18 15 12	2.58.52 3.05.07 3.16.22
		V	V54
0,04			2.59.00 3.05.16 3.16.34
			V54

TRILHAS DO ALEMÃO		34/60
0,39		3.00.10 3.06.40 3.18.19 V54
0,41		3.00.14 3.06.45 3.18.25 V54
0,54		3.00.40 3.07.16 3.19.04 V54
0,56		3.00.44 3.07.21 3.19.10 V54
0,62		3.00.56 3.07.35 3.19.28 V54
GÁZZZZZ		
0,66		3.01.04 3.07.45 3.19.40 V54
0,87		3.01.46 3.08.35 3.20.43 V54
1,10		3.02.32 3.09.31 3.21.52 V54
1,11		3.02.34 3.09.33 3.21.55 V54
1,13		3.02.38 3.09.38 3.22.01 V54
1,16		3.02.44 3.09.45 3.22.10 V54

TRILHAS DO ALEMÃO		35/60
1,23		3.02.58 3.10.02 3.22.31 V54
1,28		3.03.08 3.10.14 3.22.46 V54
1,33		3.03.18 3.10.26 3.23.01 V54
1,37		3.03.26 3.10.35 3.23.13 V54
1,38		3.03.28 3.10.38 3.23.16 V54
1,46		3.03.44 3.10.57 3.23.40 V54
1,48		3.03.48 3.11.02 3.23.46 V54
1,54		3.04.00 3.11.16 3.24.04 V54
GÁZZZZZ		
1,57		3.04.06 3.11.23 3.24.13 V54
1,79		3.04.50 3.12.16 3.25.19 V54
2,02		3.05.36 3.13.11 3.26.28 V54

TRILHAS DO ALEMÃO		36/60
2,03		3.05.38 3.13.14 3.26.31 V54
2,05		3.05.42 3.13.19 3.26.37 V54
2,08		3.05.48 3.13.26 3.26.46 V54
2,15		3.06.02 3.13.43 3.27.07 V54
2,18		3.06.08 3.13.50 3.27.16 V54
2,24		3.06.20 3.14.04 3.27.34 V54
2,25		3.06.22 3.14.07 3.27.37 V54
2,27		3.06.26 3.14.11 3.27.43 V54
2,52		3.07.16 3.15.11 3.28.58 V54
2,57		3.07.26 3.15.23 3.29.13 V54
2,63		3.07.38 3.15.38 3.29.31 V54

TRILHAS DO ALEMÃO		37/60	
Deslocamento			
2,76		3.08.04 3.16.09 3.30.10	V54
0,00		2' 3.08.04 2' 3.16.09 2' 3.30.10	D D55
0,03			D55
0,15		21 3.10.04 18 3.18.09 15 3.32.10	V V56
0,22		3.10.16 3.18.23 3.32.27	V56
0,25		3.10.21 3.18.29 3.32.34	V56
0,27		3.10.25 3.18.33 3.32.39	V56
0,30		3.10.30 3.18.39 3.32.46	V56
CAPIM			
0,37		3.10.42 3.18.53 3.33.03	V56
Deslocamento			
0,58		3.11.18 3.19.35 3.33.53	V56
0,00		5' 3.11.18 5' 3.19.35 5' 3.33.53	D D57

TRILHAS DO ALEMÃO		38/60	
0,33			D57
0,78			D57
1,06			D57
1,28			D57
PREFERENCIAL			
1,46			D57
PREFERENCIAL			
1,90			D57
COLEGIO KENEDY			
2,08			D57
2,26			D57
Neutralizado			
2,67		35' 3.16.18 30' 3.24.35 25' 3.38.53	N N58
PIZZARIA BLACK BURGER			

TRILHAS DO ALEMÃO		39/60	
Deslocamento			
0,00		10' 3.51.18 10' 3.54.35 10' 4.03.53	D D59
0,05			D59
0,38			D59
COLEGIO KENEDY			
0,55			D59
PREFERENCIAL			
0,74			D59
1,35			D59
1,58			D59
APAE			
1,66			D59
2,17			D59
2,76			D59
LINHA DO TREM			
2,91			D59

TRILHAS DO ALEMÃO		40/60	
3,45		396	D59
MANGA			
3,49		397	D59
0,00		18 4.01.18 15 4.04.35 12 4.13.53 V V60	
0,01		398	4.01.20 4.04.37 4.13.56 V60
0,19		399	4.01.56 4.05.21 4.14.50 V60
TRONCO			
0,32		400	4.02.22 4.05.52 4.15.29 V60
0,49		401	4.02.56 4.06.33 4.16.20 V60
0,68		402	4.03.34 4.07.18 4.17.17 V60
TRONCO			
0,89		403	4.04.16 4.08.09 4.18.20 V60
0,91		404	4.04.20 4.08.13 4.18.26 V60
0,93		405	4.04.24 4.08.18 4.18.32 V60



TRILHAS DO ALEMÃO		41/60	
0,94		406	4.04.26 4.08.21 4.18.35 V60
1,12		407	4.05.02 4.09.04 4.19.29 V60
1,21		408	4.05.20 4.09.25 4.19.56 V60
1,59		409	4.06.36 4.10.57 4.21.50 V60
1,69		410	4.06.56 4.11.21 4.22.20 V60
Deslocamento			
1,81		411	4.07.20 4.11.49 4.22.56 V60
0,00		411	3' 4.07.20 3' 4.11.49 3' 4.22.56 D D61
Deslocamento			
1,24		412	4.10.20 4.14.49 4.25.56 D61
0,00		412	1' 4.10.20 1' 4.14.49 1' 4.25.56 D D62
0,11		413	D62
0,39		414	12 4.11.20 12 4.15.49 12 4.26.56 V V63







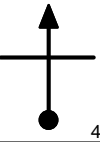
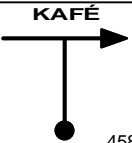
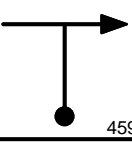
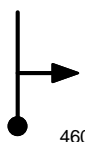
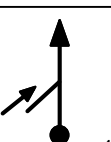

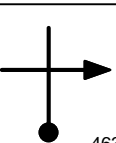
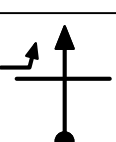
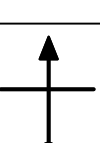
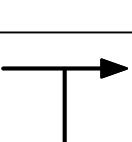
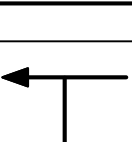
TRILHAS DO ALEMÃO		42/60	
0,40		415	4.11.23 4.15.52 4.26.59 V63
0,60		416	4.12.23 4.16.52 4.27.59 V63
0,78		417	36 4.13.17 33 4.17.46 30 4.28.53 V V64
1,20		418	4.13.59 4.18.32 4.29.44 V64
1,30		419	4.14.09 4.18.43 4.29.56 V64
Deslocamento			
1,37		420	4.14.16 4.18.51 4.30.04 V64
0,00		420	5' 4.14.16 5' 4.18.51 5' 4.30.04 D D65
FAZENDA JANETA			
0,87		421	D65
2,99		422	D65
3,13		423	D65
0,00		423	36 4.19.16 33 4.23.51 30 4.35.04 V V66

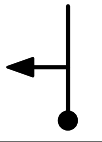



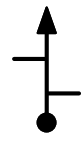

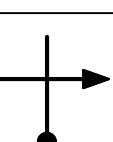
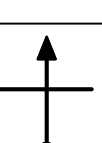
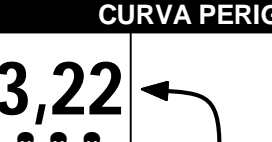

TRILHAS DO ALEMÃO		43/60
0,33		4.19.49 4.24.27 4.35.44 V66
0,56		4.20.12 4.24.52 4.36.11 V66
0,86		4.20.42 4.25.25 4.36.47 V66
0,94		4.20.50 4.25.33 4.36.57 V66
SEDE DA FAZENDA		
1,09		4.21.05 4.25.50 4.37.15 V66
LARANJA		
1,12		4.21.08 4.25.53 4.37.19 V66
1,56		4.21.52 4.26.41 4.38.11 V66
1,60		4.21.56 4.26.45 4.38.16 V66
1,68		4.22.04 4.26.54 4.38.26 V66
1,71		4.22.07 4.26.57 4.38.29 V66
1,77		4.22.13 4.27.04 4.38.37 V66

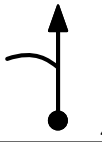

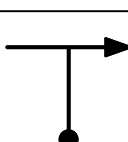
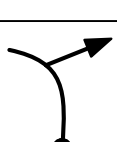
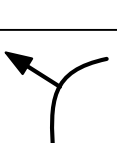

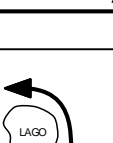
TRILHAS DO ALEMÃO		44/60
PEDREIRA		
2,39		4.23.15 4.28.12 4.39.51 V66
M.M.S.		
2,43		4.23.19 4.28.16 4.39.56 V66
2,68		4.23.44 4.28.43 4.40.26 V66
3,09		4.24.25 4.29.28 4.41.15 V66
BEIRA MATA		
3,25		4.24.41 4.29.45 4.41.34 V66
3,40		18 4.24.56 15 4.30.02 12 4.41.52 V V67
3,50		4.25.16 4.30.26 4.42.22 V67
3,52		4.25.20 4.30.31 4.42.28 V67
3,73		4.26.02 4.31.21 4.43.31 V67
3,76		4.26.08 4.31.28 4.43.40 V67
3,83		4.26.22 4.31.45 4.44.01 V67



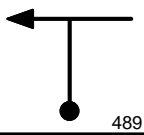
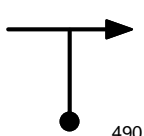
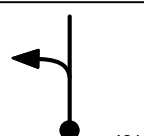
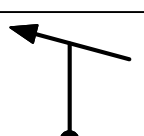
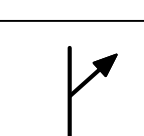
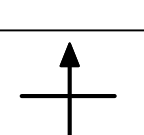

TRILHAS DO ALEMÃO		45/60
3,93		4.26.42 4.32.09 4.44.31 V67
3,95		4.26.46 4.32.14 4.44.37 V67
CHIFRES		
4,03		4.27.02 4.32.33 4.45.01 V67
4,34		4.28.04 4.33.47 4.46.34 V67
4,54		4.28.44 4.34.35 4.47.34 V67
4,64		36 4.29.04 33 4.34.59 30 4.48.04 V V68
4,75		4.29.15 4.35.11 4.48.17 V68
5,09		4.29.49 4.35.48 4.48.58 V68
5,15		4.29.55 4.35.55 4.49.05 V68
5,17		4.29.57 4.35.57 4.49.08 V68
5,41		4.30.21 4.36.23 4.49.37 V68

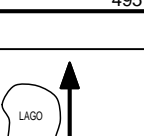
TRILHAS DO ALEMÃO		46/60
5,63		4.30.43 4.36.47 4.50.03 V68
6,03		4.31.23 4.37.31 4.50.51 V68
6,14		4.31.34 4.37.43 4.51.04 V68
7,00		4.33.00 4.39.17 4.52.47 V68
7,01		4.33.01 4.39.18 4.52.49 V68
7,07		4.33.07 4.39.24 4.52.56 V68
7,29		4.33.29 4.39.48 4.53.22 V68
7,40		4.33.40 4.40.00 4.53.35 V68
7,81		4.34.21 4.40.45 4.54.25 V68
8,01		4.34.41 4.41.07 4.54.49 V68
8,12		4.34.52 4.41.19 4.55.02 V68

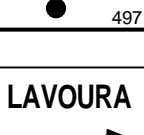
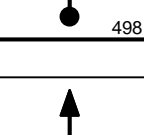
TRILHAS DO ALEMÃO		47/60
8,19		4.34.59 4.41.27 4.55.10 V68
8,32		4.35.12 4.41.41 4.55.26 V68
Neutralizado		
8,35		5' 4.35.15 3' 4.41.44 2' 4.55.29 N N69
		
0,00	N	45 4.40.15 42 4.44.44 39 4.57.29 V V70
0,08		4.40.21 4.44.51 4.57.37 V70
0,25		4.40.35 4.45.05 4.57.52 V70
1,25		4.41.55 4.46.31 4.59.25 V70
2,19		4.43.10 4.47.52 5.00.51 V70
CURVA PERIGOSA		
3,22		4.44.32 4.49.20 5.02.27 V70
3,65		4.45.07 4.49.57 5.03.06 V70

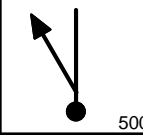
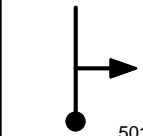
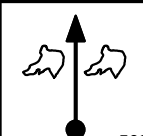
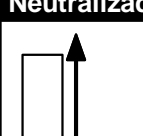
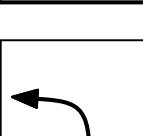
TRILHAS DO ALEMÃO		48/60
4,27		4.45.56 4.50.50 5.04.03 V70
4,42		4.46.08 4.51.03 5.04.17 V70
5,09		4.47.02 4.52.00 5.05.19 V70
5,35		21 4.47.23 18 4.52.23 15 5.05.43 V V71
5,50		4.47.49 4.52.53 5.06.19 V71
5,53		4.47.54 4.52.59 5.06.26 V71
5,73		4.48.28 4.53.39 5.07.14 V71
Neutralizado		
5,77		3' 4.48.35 2' 4.53.47 1' 5.07.24 N N72
5,77	N	21 4.51.35 18 4.55.47 15 5.08.24 V V73
5,82		4.51.43 4.55.57 5.08.36 V73
5,83		4.51.45 4.55.59 5.08.38 V73

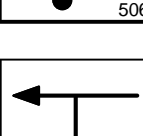
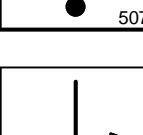
TRILHAS DO ALEMÃO		49/60	
5,87		36 33 30 V	4.51.52 4.56.07 5.08.48 V74
5,93			4.51.58 4.56.13 5.08.55 V74
6,01			4.52.06 4.56.22 5.09.05 V74
6,43		33 30 27 V	4.52.48 4.57.08 5.09.55 V75
6,49			4.52.54 4.57.15 5.10.03 V75
6,68			4.53.15 4.57.38 5.10.28 V75
PARA O LAGO			
6,94			4.53.44 4.58.09 5.11.03 V75
6,95			4.53.45 4.58.10 5.11.04 V75
6,99			4.53.49 4.58.15 5.11.10 V75
7,48			4.54.42 4.59.14 5.12.15 V75
7,87			4.55.25 5.00.01 5.13.07 V75

TRILHAS DO ALEMÃO		50/60	
8,01			4.55.40 5.00.17 5.13.26 V75
GÁZZZZZ			
8,06			4.55.46 5.00.23 5.13.32 V75
PEDRAS			
8,11			4.55.51 5.00.29 5.13.39 V75
TANQUE DE COMBUSTÍVEL			
Neutralizado			
8,15		3' 2' 1' N	4.55.56 5.00.34 5.13.44 N76
0,00	N	9 9 9 V	4.58.56 5.02.34 5.14.44 V77
0,02			4.59.04 5.02.42 5.14.52 V77
NA VALA			
0,04			4.59.12 5.02.50 5.15.00 V77
0,08		15 12 12 V	4.59.28 5.03.06 5.15.16 V78
0,12			4.59.37 5.03.18 5.15.28 V78
GÁZZZZZ			
0,31			5.00.23 5.04.15 5.16.25 V78

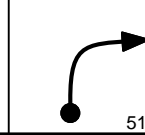
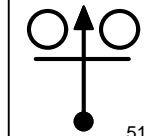
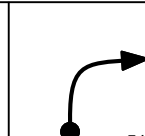
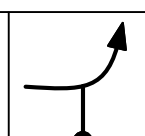
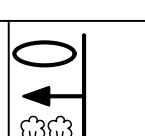
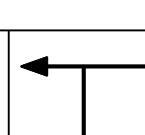
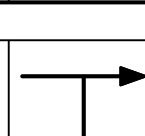
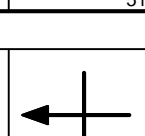
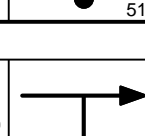
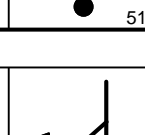
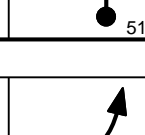
TRILHAS DO ALEMÃO		51/60	
CURVA DE NÍVEL			
0,38		21 18 15 V	5.00.40 5.04.36 5.16.46 V79
0,48			5.00.57 5.04.56 5.17.10 V79
0,68			5.01.31 5.05.36 5.17.58 V79
0,71			5.01.36 5.05.42 5.18.06 V79
0,77			5.01.46 5.05.54 5.18.20 V79
1,12		36 33 30 V	5.02.46 5.07.04 5.19.44 V80
1,22			5.02.56 5.07.15 5.19.56 V80
1,44			5.03.18 5.07.39 5.20.22 V80
1,76		45 42 39 V	5.03.50 5.08.14 5.21.01 V81
1,78			5.03.52 5.08.16 5.21.03 V81
2,76		18 15 12 V	5.05.10 5.09.40 5.22.33 V82



TRILHAS DO ALEMÃO		52/60	
2,85		5.05.28 5.10.01 5.23.00	V82
2,98		45 5.05.54 42 5.10.32 39 5.23.39	V V83
PARALELEPIPEDO			
O			
Deslocamento			
3,68		2' 5.06.50 2' 5.11.32 2' 5.24.44	D D84
QUEBRA MOLA			
4,60			D84
Deslocamento			
4,81			D84
0,00		1' 5.08.50 1' 5.13.32 1' 5.26.44	D D85
0,33		42 5.09.50 39 5.14.32 36 5.27.44	V V86
0,47		5.10.02 5.14.45 5.27.58	V86
0,77		5.10.28 5.15.13 5.28.28	V86
3,20		5.13.56 5.18.57 5.32.31	V86



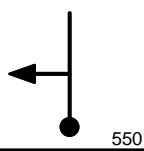
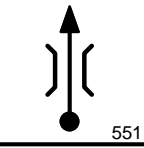
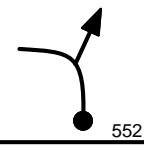
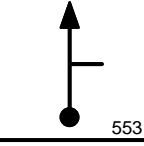
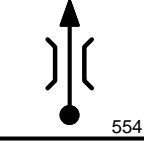
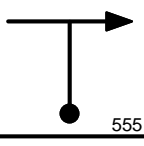
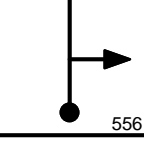
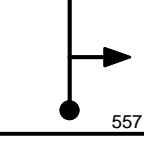
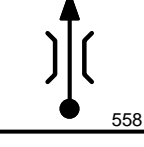
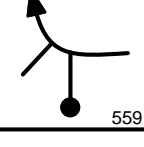
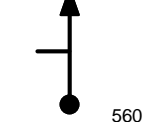

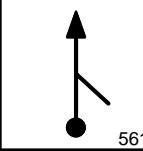
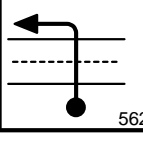
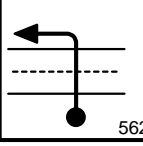
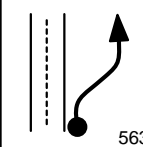
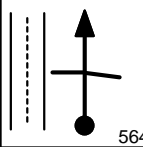
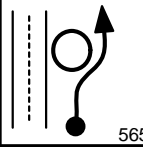
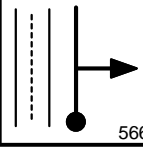
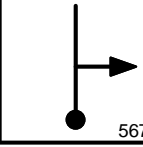
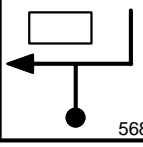
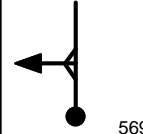

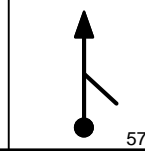
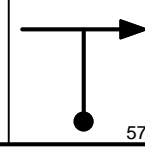
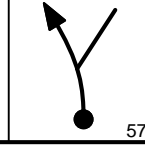
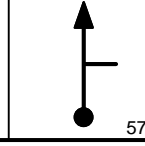
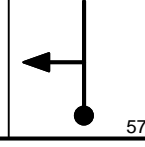
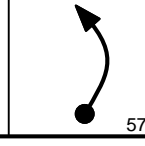
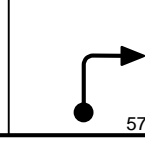
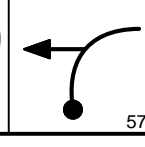
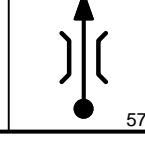
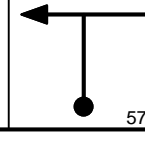
TRILHAS DO ALEMÃO		53/60	
3,90		5.14.56 5.20.02 5.33.41	V86
4,07		5.15.11 5.20.18 5.33.58	V86
5,06		5.16.36 5.21.49 5.35.37	V86
5,10		5.16.39 5.21.53 5.35.41	V86
5,17		36 5.16.45 33 5.21.59 30 5.35.48	V V87
5,50		5.17.18 5.22.35 5.36.27	V87
5,78		5.17.46 5.23.06 5.37.01	V87
5,90		5.17.58 5.23.19 5.37.15	V87
6,04		5.18.12 5.23.34 5.37.32	V87
6,14		5.18.22 5.23.45 5.37.44	V87
7,11		5.19.59 5.25.31 5.39.41	V87

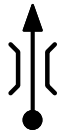
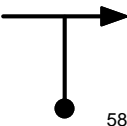

TRILHAS DO ALEMÃO		54/60	
0,00		30 5.19.59 27 5.25.31 24 5.39.41	V V88
0,28		5.20.33 5.26.08 5.40.23	V88
0,75		5.21.29 5.27.11 5.41.33	V88
1,22		5.22.26 5.28.13 5.42.44	V88
BEIRA A MATA			
1,67		5.23.20 5.29.13 5.43.51	V88
2,13		5.24.15 5.30.15 5.45.00	V88
2,25		5.24.29 5.30.31 5.45.18	V88
2,45		5.24.53 5.30.57 5.45.48	V88
2,61		5.25.12 5.31.19 5.46.12	V88
4,27		5.28.32 5.35.00 5.50.21	V88
0,00		45 5.28.32 42 5.35.00 39 5.50.21	V V89

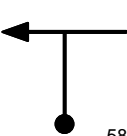
TRILHAS DO ALEMÃO		55/60
2,23		5.31.30 5.38.11 5.53.47 V89
3,16		5.32.44 5.39.31 5.55.13 V89
3,21		5.32.48 5.39.35 5.55.17 V89
3,27		5.32.53 5.39.40 5.55.23 V89
3,75		39 5.33.32 36 5.40.22 33 5.56.07 V V90
3,77		5.33.34 5.40.24 5.56.09 V90
3,91		5.33.46 5.40.38 5.56.25 V90
4,66		5.34.56 5.41.53 5.57.47 V90
4,68		5.34.58 5.41.55 5.57.49 V90
4,76		5.35.05 5.42.03 5.57.57 V90
5,30		5.35.55 5.42.57 5.58.56 V90

TRILHAS DO ALEMÃO		56/60
5,66		5.36.28 5.43.33 5.59.36 V90
RODOVIA, PELO ACOSTAMENTO		
6,40		5.37.36 5.44.47 6.00.56 V90
0,00		51 5.37.36 48 5.44.47 45 6.00.56 V V91
0,30		5.37.57 5.45.09 6.01.20 V91
1,02		5.38.48 5.46.03 6.02.18 V91
2,62		5.40.41 5.48.03 6.04.26 V91
2,69		5.40.46 5.48.08 6.04.32 V91
3,26		5.41.26 5.48.51 6.05.17 V91
3,56		33 5.41.48 30 5.49.14 27 6.05.41 V V92
3,79		5.42.13 5.49.41 6.06.12 V92

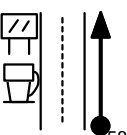
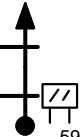
TRILHAS DO ALEMÃO		57/60
3,95		5.42.30 5.50.00 6.06.33 V92
4,43		5.43.22 5.50.58 6.07.37 V92
4,52		5.43.32 5.51.09 6.07.49 V92
5,01		5.44.26 5.52.08 6.08.54 V92
5,08		27 5.44.33 24 5.52.16 21 6.09.04 V V93
5,17		5.44.45 5.52.29 6.09.19 V93
5,38		5.45.13 5.53.01 6.09.55 V93
5,50		5.45.29 5.53.19 6.10.16 V93
5,54		5.45.35 5.53.25 6.10.23 V93
5,57		5.45.39 5.53.29 6.10.28 V93
5,72		5.45.59 5.53.52 6.10.54 V93

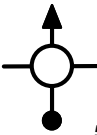
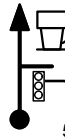
TRILHAS DO ALEMÃO		58/60	
5,74			5.46.01 5.53.55 6.10.57 V93
5,76		45 42 39 V	5.46.04 5.53.58 6.11.00 V94
6,48			5.47.02 5.55.00 6.12.07 V94
7,09			5.47.50 5.55.52 6.13.03 V94
7,26		51 48 45 V	5.48.04 5.56.07 6.13.19 V95
8,37			5.49.22 5.57.30 6.14.48 V95
10,27			5.51.37 5.59.52 6.17.20 V95
Deslocamento			
10,65			5.52.03 6.00.21 6.17.50 V95
0,00		20' 20' 20' D	5.52.03 6.00.21 6.17.50 D96
POSTO ESSO			
1,54			D96
5,96			D96

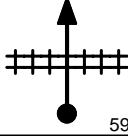
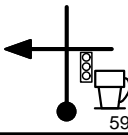
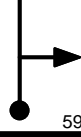
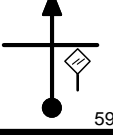
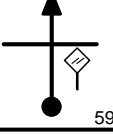
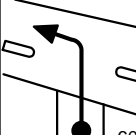
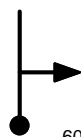
TRILHAS DO ALEMÃO		59/60	
TREVO			
6,47			D96
SINALEIRO RESPEITE			
6,75			D96
Q.M.			
7,51			D96
8,04			D96
TRILHO DO TREM			
8,12			D96
SINALEIRO			
8,16			D96
8,31			D96
PARE			
8,42			D96
PARE			
8,55			D96
8,62			D96
Neutralizado			
8,79		0' 0' 0' N	6.12.03 6.20.21 6.37.50 N97

TRILHAS DO ALEMÃO		60/60	
FIM DA PROVA !!			
			
Planilha gerada pelo programa TotemPlanilha que foi criado pela Totem.			
Esta é uma das formas que a Totem participa da evolução do Off Road.			
www.totemonline.com.br			
ROLANDIA_R03.pla			
ADC5245B905		v5.39	