



5º ENDURO DE REGULARIDADE DE JANDAIA DO SUL

PROVA: ENDURO DO PADROEIRO SÃO JOÃO BATISTA

ATENÇÃO PILOTOS, REGIÃO CANAVIEIRA, TRÁFEGO DE CAMINHÕES NAS PRINCIPAIS.

Vistoria das 07:00hs as 07:45hs.

Intervalo para categorias MASTER será de 40 em 40 Segundos  
DEMAIS CATEGORIA será de 20 em 20 segundos

- PRESERVE O VERDE E RESPEITE AS PROPRIEDADES ALHEIAS.
- TODAS AS ESTRADAS ESTÃO ABERTAS AO TRANSITO.

DESDE JA AGRADECEMOS A TODOS PILOTOS

	<b>ATENÇÃO</b>
	<b>CUIDADO</b>
	<b>PERIGO</b>

Tempo de Prova	
MAS / SEN	06:04:35
OVR / JUN	06:17:54
NOV / TUR	06:38:09



**AFERIÇÃO**

0,00		1	F	Afer
------	--	---	---	------

AV. GETULIO VARGAS

0,03		2		Afer
------	--	---	--	------

1º FAROL, RESPEITE!!!!

0,27		3		Afer
------	--	---	--	------

2º FAROL, RESPEITE

0,40		4		Afer
------	--	---	--	------

ABASTEÇA NA VOLTA

0,73		5		Afer
------	--	---	--	------

Q.M.

0,96		6		Afer
------	--	---	--	------

FAIXA DE PEDESTRE

1,209		7		Afer
-------	--	---	--	------

**AFERIÇÃO 1,209**

1,23		8		Afer
------	--	---	--	------

--	--	--	--	--

**Início de Prova**

**ATENÇÃO PILOTOS!!!!**  
REGIÃO CANAVIEIRA, TRÁFEGO DE CAMINHÕES NAS PRINCIPAIS.

Deslocamento

0,00		9	D	T1	5'	0.00.00
					5'	0.00.00
					5'	0.00.00

0,03		10		T1
------	--	----	--	----

1º FAROL, RESPEITE!!!!

0,27		11		T1
------	--	----	--	----

2º FAROL, RESPEITE

0,40		12		T1
------	--	----	--	----

0,73		13		T1
------	--	----	--	----

0,96		14		T1
------	--	----	--	----

1,23		15		T1
------	--	----	--	----

Q.M.

1,55		16		T1
------	--	----	--	----

1,71		17		T2	21	0.05.00
					18	0.05.00
					15	0.05.00

0,00		18		T2
------	--	----	--	----

0,07		19		T2
------	--	----	--	----

0,16		20		T2
------	--	----	--	----



0,23		20		T2
------	--	----	--	----

DOMINGO		4/62	
0,33			T2
0,45			T2
0,57			T2
<b>CRUZE</b>			
0,58			T2
1,16			T2
<b>ENTRE NO RIO</b>			
1,17			T2
<b>SAIA</b>			
1,18			T2
1,19			T2
<b>BREJO</b>			
1,35			T2
1,37			T2
<b>BREJO</b>			
1,40			T2
1,42			T2

DOMINGO		5/62	
1,43			T2
1,69			T2
1,70			T2
1,72			T2
<b>CRUZE</b>			
1,75			T2
1,79			T2
<b>ENTRE NO RIO</b>			
1,83			T2
<b>SAIA</b>			
1,84			T2
1,89		30 0.10.24 27 0.11.18 24 0.12.34 V	T3
1,92			T3
2,04			T3
2,09			T3
2,11		45 0.10.50 42 0.11.47 39 0.13.07 V	T4
<b>EROSÕES</b>			

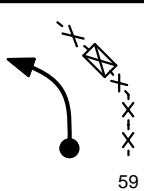
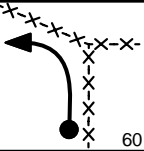
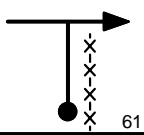
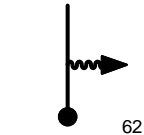
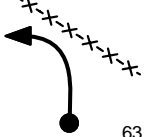
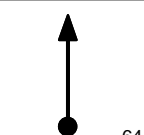
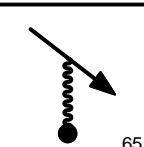
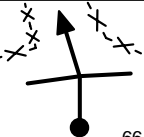
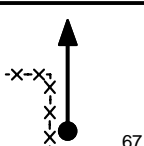
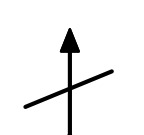
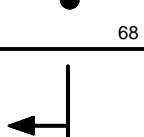
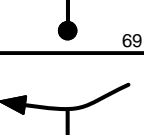
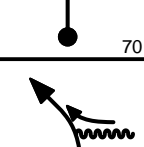
DOMINGO		6/62	
2,69			T4
2,86			T4
3,06			T4
<b>Neutralizado</b>			
3,87		2' 0.13.11 2' 0.14.18 2' 0.15.49 N	T5
0,00	<b>N</b>	48 0.15.11 45 0.16.18 42 0.17.49 V	T6
0,24			T6
0,76			T6
1,29			T6
1,59			T6
1,73			T6
1,92		MATA	T6
2,14			T6
2,28			T6

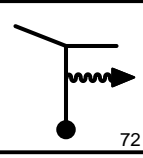
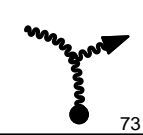
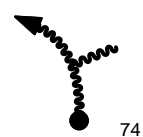
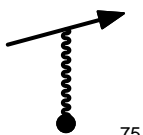
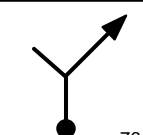
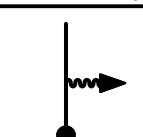
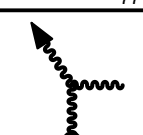
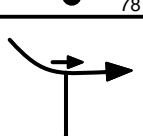
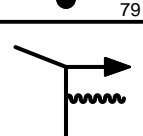
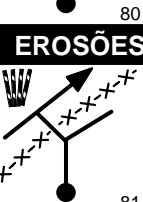
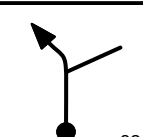
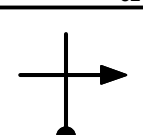
DOMINGO		7/62	
2,44		45 0.18.14 42 0.19.33 39 0.21.18	
0,00		V T7	
0,09			
PPAL			
0,41			
0,77		18 0.19.16 15 0.20.39 12 0.22.29	
1,05			
1,20			
1,46		54 0.21.34 51 0.23.25 48 0.25.56	
2,60			
3,21			
3,69		48 0.24.02 45 0.26.02 42 0.28.44	
0,00		V T10	
0,16			
0,20			
0,51			



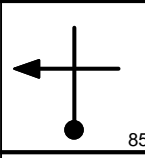
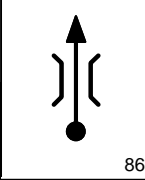
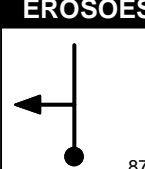
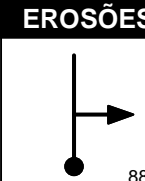
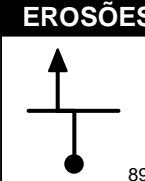
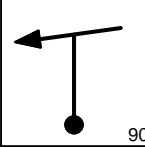
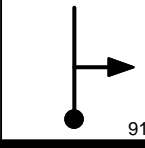
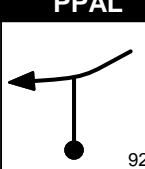
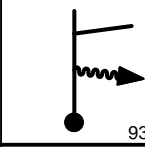
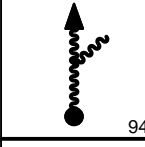
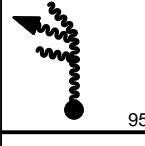
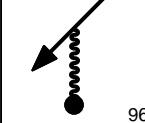



DOMINGO		8/62	
0,61		18 0.24.48 15 0.26.51 12 0.29.36	
0,69			
0,78			
0,82			
0,85			
0,87			
0,95			
1,02		48 0.26.10 45 0.28.30 42 0.31.39	
1,13			
EROSÕES			
1,20			
1,62			
1,86			
EROSÕES			
2,69			

DOMINGO		9/62	
3,14			
3,18		42 0.28.52 39 0.31.22 36 0.34.44	
0,00		V T13	
EROSÕES			
0,02			
EROSÕES			
0,21			
EROSÕES			
0,40			
0,66			
0,70			
PPAL			
0,78			
0,89			
0,99			
1,01			
1,06			

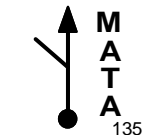
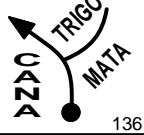
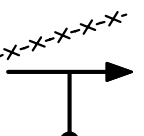

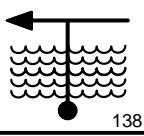

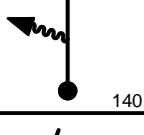
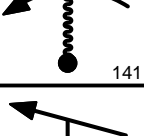
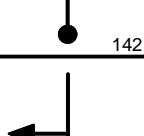
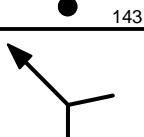
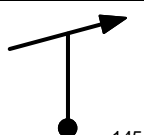
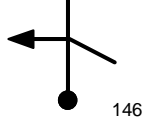
DOMINGO		10/62	
1,17		97	T13
1,58		98	T13
1,74		99	T13
<b>CRUZE</b>			
1,77		100	T13
1,82		101	T13
<b>PPAL</b>			
2,11		102	T13
2,52		103	T13
2,57		51 0.32.32 48 0.35.20 45 0.39.01 V	T14
3,07		21 0.33.08 18 0.35.57 15 0.39.41 V	T15
3,44		106	T15
3,55		107	T15
3,62		39 0.34.42 36 0.37.47 33 0.41.53 V	T16
3,75		109	T16



DOMINGO		11/62	
3,78		110	T16
<b>Neutralizado</b>			
3,97		2' 0.35.14 2' 0.38.22 2' 0.42.31 N	T17
0,00	<b>N</b>	54 0.37.14 51 0.40.22 48 0.44.31 V	T18
0,10		113	T18
0,29		114	T18
0,56		115	T18
1,14		116	T18
<b>ATENÇÃO!!! PODE HAVER M.S.C.</b>			
<b>Deslocamento</b>			
1,87		2' 0.39.19 2' 0.42.34 2' 0.46.51 D	T19
1,98		118	T19
2,29		48 0.41.19 45 0.44.34 42 0.48.51 V	T20
3,17		120	T20
3,35		121	T20

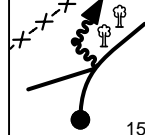
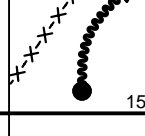
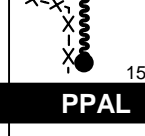
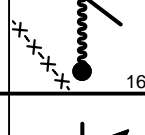
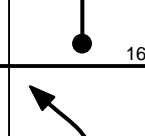
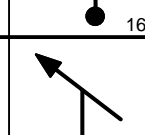
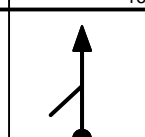
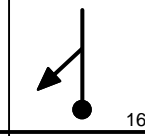
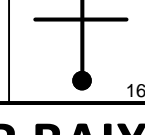

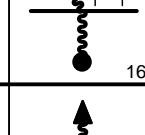

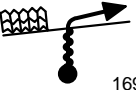
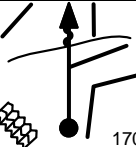
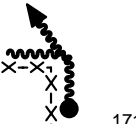
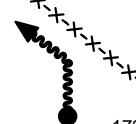
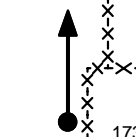
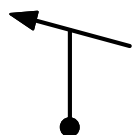
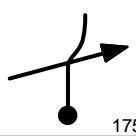
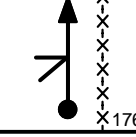
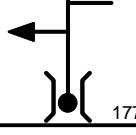
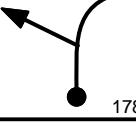
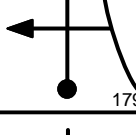
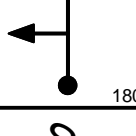

DOMINGO		12/62	
3,37		122	T20
3,50		54 0.42.50 51 0.46.11 48 0.50.35 V	T21
0,00		123	
0,23		124	T21
0,57		125	T21
0,82		126	T21
0,87		127	T21
1,03		128	T21
1,93		129	T21
2,42		130	T21
2,62		45 0.45.44 42 0.49.16 39 0.53.52 V	T22
2,92		132	T22
2,97		133	T22
3,02		134	T22



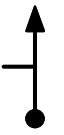
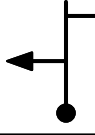
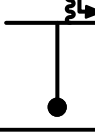
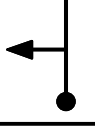

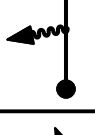

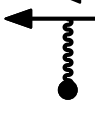
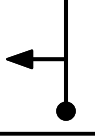
DOMINGO		13/62	
3,11			T22
3,28			T22
<b>PARA O RIO</b>			
3,70		39 0.47.11 36 0.50.48 33 0.55.31 V	T23
0,00			
<b>CRUZE E BEIRE</b>			
0,04			T23
0,61			T23
<b>NA MATA</b>			
0,78			T23
0,95		45 0.48.39 42 0.52.23 39 0.57.15 V	T24
1,33			T24
1,55			T24
2,16			T24
2,31			T24
2,65			T24

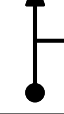

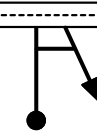
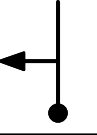
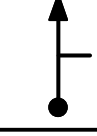

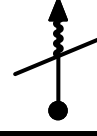
DOMINGO		14/62	
2,93			T24
<b>PPAL</b>			
3,13		54 0.51.33 51 0.55.30 48 1.00.36 V	T25
3,18			T25
<b>PPAL</b>			
3,31			T25
4,16			T25
4,22			T25
<b>ATENÇÃO!!! CRUZE COM MUITO CUIDADO</b>			
<b>Deslocamento</b>			
4,28		2' 0.52.50 2' 0.56.51 2' 1.02.02 D	T26
0,00		☠☠☠	
0,01		48 0.54.50 45 0.58.51 42 1.04.02 V	T27
<b>TRÁFEGO DE CAMINHÕES</b>			
0,07			T27
0,63			T27
<b>EUCALIPTO</b>			

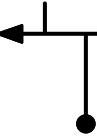
DOMINGO		15/62	
0,75		21 0.55.45 18 0.59.51 15 1.05.06 V	T28
0,90			T28
1,08			T28
<b>PPAL</b>			
1,39		39 0.57.35 36 1.01.59 33 1.07.39 V	T29
1,53			T29
1,60			T29
1,70			T29
1,88			T29
2,18		27 0.58.48 24 1.03.18 21 1.09.06 V	T30
2,28			T30
<b>POR BAIXO DO PÉ DE MANGA</b>			
2,35			T30
2,41			T30
<b>PARALELEPIEDO</b>			

DOMINGO		16/62	
2,59		169	T30
<b>NA TRILHA</b>			
2,64		21 18 15	0.59.49 1.04.27 1.10.24
	V		T31
2,75		171	T31
2,88		36 33 30	1.00.30 1.05.15 1.11.22
	V		T32
3,04		173	T32
<b>PPAL</b>			
3,76		45 42 39	1.01.58 1.06.51 1.13.08
0,00	V		T33
0,39		30 27 24	1.02.29 1.07.24 1.13.44
	V		T34
0,60		176	T34
0,67		48 45 42	1.03.03 1.08.01 1.14.26
	V		T35
0,91		178	T35
1,50		179	T35
1,53		180	T35
2,13		181	T35

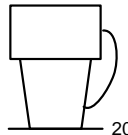
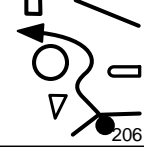

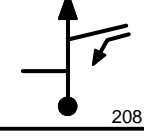
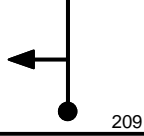
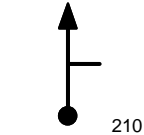

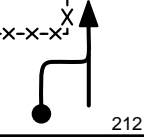
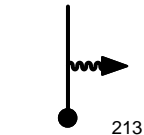
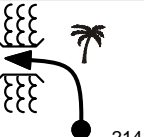

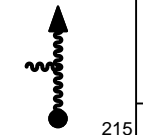
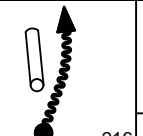
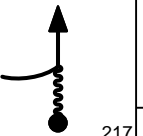
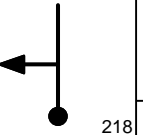
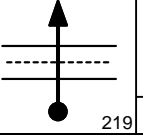
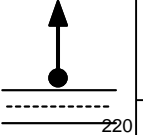
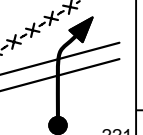
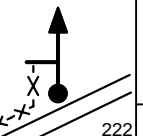
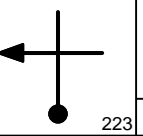
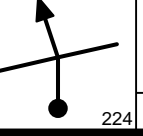
DOMINGO		17/62	
2,49		182	T35
2,62		183	T35
2,78		184	T35
2,93		185	T35
3,20		186	T35
3,34		27 24 21	1.06.23 1.11.35 1.18.14
	V		T36
3,44		188	T36
3,80		189	T36
4,08		51 48 45	1.08.02 1.13.26 1.20.21
0,00	V		T37
0,13		191	T37
0,41		192	T37
0,55		193	T37
0,60		194	T37

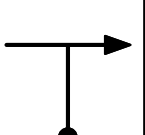
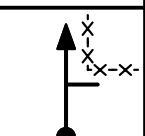
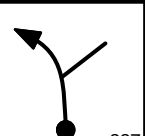
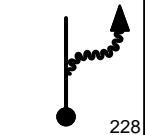
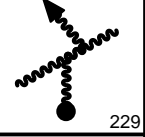
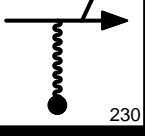
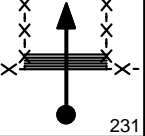
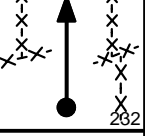
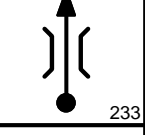
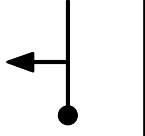
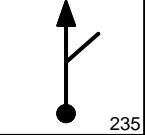
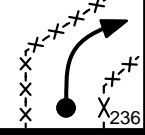

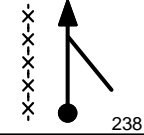
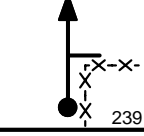
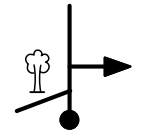
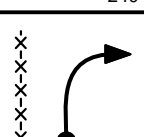
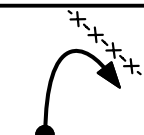
DOMINGO		18/62	
1,23		195	T37
1,38		196	T37
2,12		197	T37
2,40		27 24 21	1.10.51 1.16.26 1.23.33
	V		T38
<b>SUBA O BARRANCO</b>			
2,60		199	T38
<b>PARA O CRUZEIRO</b>			
2,68		200	T38
2,72		201	T38
<b>PPAL</b>			
2,80		202	T38
<b>RODOVIA CUIDADO</b>			
<b>Deslocamento</b>			
2,83		1' 1' 1'	1.11.49 1.17.31 1.24.47
	D		T39
<b>POSTO</b>			
2,88		204	T39
<b>ABASTEÇA!!!</b>			
<b>Neutralizado</b>			

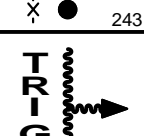
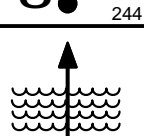

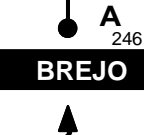
DOMINGO		19/62	
2,94		12' 1.12.49 10' 1.18.31 8' 1.25.47	N T40
<b>TOTEM</b>			
ZERE NO ORELHÃO			
Deslocamento			
0,00		1' 1.24.49 1' 1.28.31 1' 1.33.47	D T41
0,07			T41
M.S.C.			
0,17		48 1.25.49 45 1.29.31 42 1.34.47	V T42
0,35			T42
0,92			T42
CUIDADO TOCOS			
1,05			T42
PPAL			
1,28			T42
1,30		27 1.27.13 24 1.31.01 21 1.36.24	V T43
BANANA			
1,36			T43

DOMINGO		20/62	
1,40			T43
CUIDADO			
1,48			T43
1,77			T43
2,32			T43
CRUZE COM MUITO CUIDADO!!!			
Deslocamento			
2,42		4' 1.29.43 4' 1.33.49 4' 1.39.36	D T44
VILA RURAL ADEMAR PINI			
2,43			T44
PARALELEPIPEDO			
2,95			T44
2,98		54 1.33.43 51 1.37.49 48 1.43.36	V T45
3,21			T45
3,48			T45
PPAL			

DOMINGO		21/62	
3,78		57 1.34.36 54 1.38.45 51 1.44.36	V T46
0,00			T46
1,60		18 1.36.17 15 1.40.32 12 1.46.29	V T47
DESCE			
1,73			T47
1,81			T47
1,83		48 1.37.03 45 1.41.27 42 1.47.38	V T48
M.B.			
1,94			T48
2,82			T48
3,12			T48
4,06		51 1.39.50 48 1.44.26 45 1.50.49	V T49
0,00			T49
0,25			T49
PPAL			

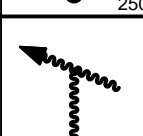
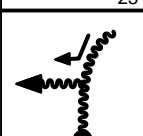
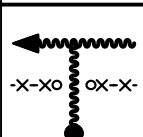
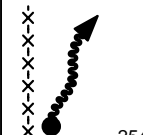
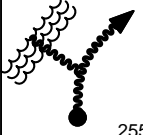
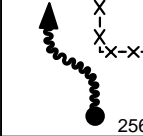
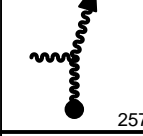
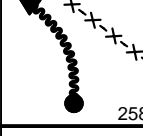
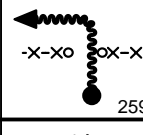
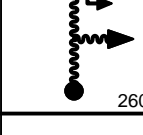
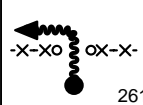
DOMINGO		22/62	
1,80		54 1.41.57 51 1.46.41 48 1.53.13	V T50
2,53			T50
3,03			T50
3,62		27 1.43.59 24 1.48.49 21 1.55.29	V T51
0,00			T51
0,34			T51
0,60			T51
<b>RESPEITE O TRIGO</b>			
0,75			T51
1,12			T51
1,14			T51
<b>BEIRE A MATA</b>			
1,18			T51
<b>BREJO</b>			
1,23			T51
<b>CONTORNE A REPRESA</b>			
1,28			T51
<b>BREJO, GÁZZZZ!!!!</b>			

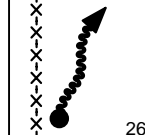
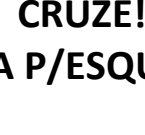
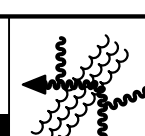
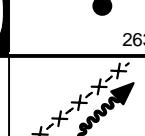
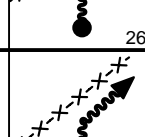
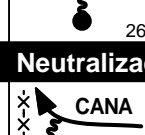
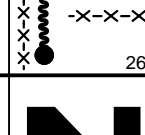
DOMINGO		23/62	
1,32			T51
<b>NA MATA</b>			
1,34		18 1.46.57 15 1.52.10 12 1.59.19	V T52
1,69			T52
1,74			T52
1,91			T52
1,96			T52
1,98			T52
2,36			T52
2,37			T52
2,39			T52
2,43			T52
2,53			T52
2,71			T52

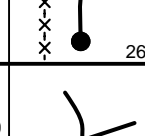
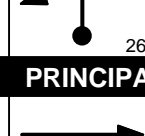
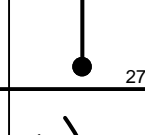
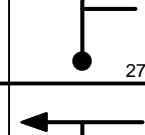



DOMINGO		24/62	
2,75			T52
<b>CRUZE!!! SAIA P/ESQUERDA</b>			
2,78		18 1.51.45 15 1.57.56 12 2.06.31	V T53
0,00			T53
0,01		12 1.51.47 12 1.57.58 9 2.06.34	V T54
0,25			T54
<b>Neutralizado</b>			
0,39		3' 1.53.41 3' 1.59.52 3' 2.09.06	N T55
0,39		45 1.56.41 42 2.02.52 39 2.12.06	V T56
0,62			T56
0,66			T56
<b>PRINCIPAL</b>			
0,98		48 1.57.29 45 2.03.43 42 2.13.01	V T57
1,40			T57
1,72			T57





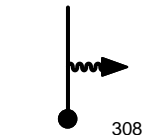

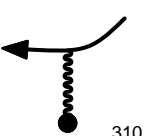
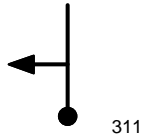
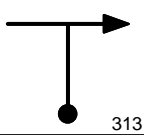

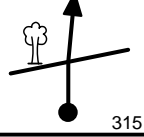
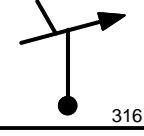
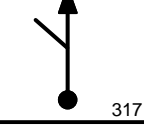
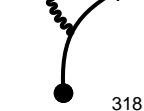

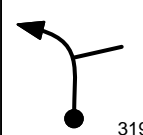
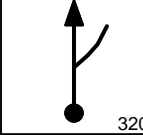
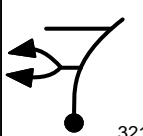
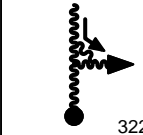
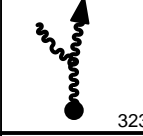
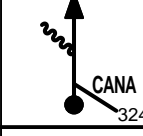
DOMINGO		25/62	
2,11		273	T57
2,48		274	T57
3,02		275	T57
3,24		276	T57
3,27		277	T57
<b>PRINCIPAL</b>			
3,44		278	T57
<b>BEIRANDO A CANA E AS ÁRVORES</b>			
3,49		39 2.00.37 36 2.07.03 33 2.16.36 V T58	279
0,00			T58
0,48			T58
0,57			T58
0,69			T58
1,23			T58
1,44			T58

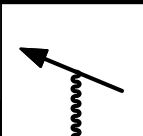
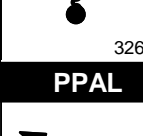
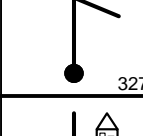
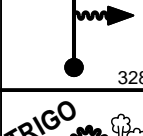
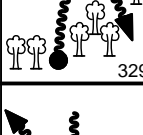
DOMINGO		26/62	
1,48		285	T58
1,65		286	T58
1,75		287	T58
1,89		288	T58
1,94		289	T58
2,53		290	T58
<b>DI NOVO</b>			
2,70		291	T58
2,88		45 2.05.03 42 2.11.51 39 2.21.50 V T59	292
3,12		293	T59
<b>PPAL</b>			
3,88			T59
3,93		45 2.06.27 42 2.13.21 39 2.23.27 V T60	295
0,00			T60
0,15			T60
0,42		39 2.07.00 36 2.13.57 33 2.24.06 V T61	297

DOMINGO		27/62	
0,66		298	T61
0,77		299	T61
<b>PRINCIPAL</b>			
<b>Deslocamento</b>			
1,40		2' 2.08.31 2' 2.15.35 2' 2.25.53 D T62	300
<b>PODE HAVER M.S.C.</b>			
2,37		301	T62
2,68		302	T62
2,79		51 2.10.31 48 2.17.35 45 2.27.53 V T63	303
3,53		27 2.11.23 24 2.18.31 21 2.28.52 V T64	304
0,00			T64
0,16		305	T64
0,39		306	T64
0,54		307	T64

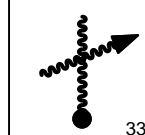
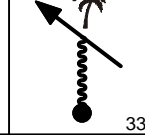
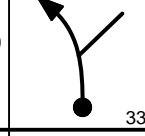
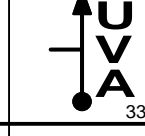
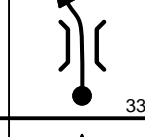
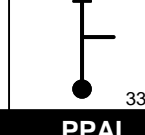
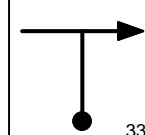
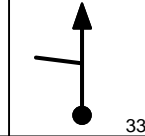
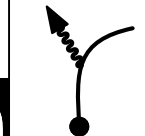
DOMINGO		28/62	
0,56		308	T64
0,69		309	T64
<b>PRINCIPAL</b>			
0,77		42 39 36 V	2.13.06 2.20.26 2.31.04 T65
1,04		311	T65
<b>EROSÃO PERIGOSA</b>			
1,36		312	T65
2,10		30 27 24 V	2.15.00 2.22.29 2.33.17 T66
<b>CUIDADO NA PRÓXIMA REFERÊNCIA</b>			
2,32		51 48 45 V	2.15.26 2.22.59 2.33.50 T67
2,49		315	T67
2,85		316	T67
2,90		317	T67
3,39		318	T67

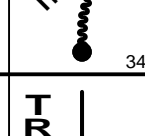
DOMINGO		29/62	
3,43		319	T67
3,52		21 18 15 V	2.16.51 2.24.29 2.35.26 T68
<b>ESCOLHA UM</b>			
3,64		321	T68
3,79		322	T68
3,89		323	T68
3,96		324	T68
4,09		325	T68
<b>PRINCIPAL</b>			
4,20		48 45 42 V	2.18.47 2.26.45 2.38.09 T69
0,00		326	
<b>PPAL</b>			
0,69		327	T69
0,75		24 21 18 V	2.19.44 2.27.45 2.39.13 T70
1,04		329	T70
1,20		330	T70

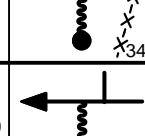
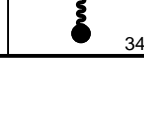
DOMINGO		30/62	
1,27		331	T70
1,31		42 39 36 V	2.21.08 2.29.21 2.41.05 T71
1,46		333	T71
1,82		334	T71
1,89		335	T71
2,55		54 51 48 V	2.22.54 2.31.15 2.43.09 T72
<b>PPAL</b>			
3,52		337	T72
3,94		338	T72
4,65		42 39 36 V	2.25.14 2.33.43 2.45.47 T73
0,00		339	
<b>RESPEITE</b>			
0,25		340	T73
0,30		341	T73
0,33		342	T73
0,66		51 48 45 V	2.26.10 2.34.44 2.46.53 T74

DOMINGO		31/62	
1,65		344	T74
2,94		345	T74
4,07		42 39 36 V	2.30.11 2.39.00 2.51.26 T75
0,00		346	
0,93		347	T75
1,07		348	T75
1,14		349	T75
1,28		350	T75
1,31		21 18 15 V	2.32.03 2.41.01 2.53.37 T76
1,37		352	T76
1,38		353	T76
1,42		354	T76
1,51		355	T76
1,54		356	T76

DOMINGO		32/62	
1,62		357	T76
1,64		358	T76
1,80		359	T76
2,02		360	T76
2,08		33 30 27 V	2.34.15 2.43.35 2.56.41 T77
2,13		362	T77
2,16		363	T77
2,19		364	T77
2,30		365	T77
2,37		366	T77
2,54		367	T77
<b>Neutralizado</b>			
2,63		2' 2' 2' N	2.35.15 2.44.41 2.57.55 T78
2,63	<b>N</b>	21 18 15 V	2.37.15 2.46.41 2.59.55 T79

DOMINGO		33/62	
2,66		370	T79
<b>NA DIREITA DO RIO</b>			
2,85		371	T79
<b>PELA ESQUERDA</b>			
2,87		372	T79
<b>NO BARRANCO</b>			
2,96		373	T79
<b>POR DENTRO</b>			
2,98		374	T79
<b>NA LAJE</b>			
3,01		375	T79
<b>POR DENTRO</b>			
3,12		376	T79
<b>PELA ESQUERDA ATÉ A LAJE</b>			
3,26		377	T79
<b>LAJE CORREDEIRA</b>			
3,28		378	T79
<b>SAIA</b>			
3,34		379	T79

DOMINGO		34/62	
3,39		45 2.39.26	
0,00		42 2.49.13	
		39 3.02.57	
		V T80	
0,15			T80
0,38			T80
<b>PPAL</b>			
0,70		51 2.40.22	
		48 2.50.13	
		45 3.04.02	
		V T81	
1,83			T81
2,17			T81
3,00		42 2.43.04	
		39 2.53.05	
		36 3.07.06	
		V T82	
<b>Deslocamento</b>			
4,67		5' 2.45.27	
0,00		5' 2.55.39	
		5' 3.09.53	
		D T83	
0,25			T83
0,76			T83
1,00			T83
<b>ORELHÃO</b>			
Neutralizado			

DOMINGO		35/62	
1,11		30' 2.50.27	
		25' 3.00.39	
		20' 3.14.53	
		N T84	
<b>TOTEM</b>			
ATENÇÃO PILOTOS!!!! FAÇAM O DESLOCAMENTO EM TEMPO HÁBIL, HÁ UMA LINHA FÉRREA P/ TRANSPOR (RISCO DE TREM)			
<b>Deslocamento</b>			
0,00		15' 3.20.27	
		15' 3.25.39	
		15' 3.34.53	
		D T85	
0,02			T85
0,19			T85
<b>ABASTEÇA</b>			
0,44			T85
<b>2º Q.M.</b>			
0,72			T85
<b>3º Q.M.</b>			
0,96			T85
<b>PONTO DE ONIBUS</b>			
1,14			T85
<b>BUEIRO</b>			
1,53			T85
<b>PARALELEPIEDO</b>			

DOMINGO		36/62	
1,56			T85
1,71			T85
1,86			T85
2,14			T85
<b>LINHA FÉRREA</b>			
2,21			T85
2,22		48 3.35.27	
		45 3.40.39	
		42 3.49.53	
		V T86	
0,00			
0,12			T86
0,28			T86
0,39			T86
0,47			T86
<b>ANTES DA RODOVIA</b>			
0,51			T86
0,77			T86
0,91			T86

DOMINGO		37/62	
<b>Deslocamento</b>			
1,19		5'	3.36.56
		5'	3.42.15
		5'	3.51.35
		D	T87
1,20		39	3.41.56
		36	3.47.15
		33	3.56.35
		V	T88
1,30			
			T88

**BEIRANDO A FERROVIA**

1,32			
			T88
1,85		42	3.42.56
		39	3.48.20
		36	3.57.46
0,00		V	T89
0,28			
			T89
<b>EROSÃO</b>			
0,30			
			T89
0,31			
			T89
0,32			
			T89
0,76			
			T89
0,96			
			T89

DOMINGO		38/62	
1,40			
			T89
1,86			
			T89
<b>PPAL</b>			
2,24		57	3.46.08
		54	3.51.46
		51	4.01.30
		V	T90
3,28			
			T90
4,04		54	3.48.02
		51	3.53.46
		48	4.03.37
0,00		V	T91
0,83			
			T91
<b>SITIO NOSSA SENHORA APARECIDA</b>			
1,89			
			T91
<b>SITIO SANTA RITA DE CASSIA</b>			
3,15			
			T91
<b>SITIO RENASCER</b>			
4,10			
			T91
4,55		51	3.53.05
		48	3.59.08
		45	4.09.18
0,00		V	T92

DOMINGO		39/62	
0,25			
			T92
1,14			
			T92
1,35		39	3.54.41
		36	4.00.49
		33	4.11.06
		V	T93
<b>PPAL</b>			
2,04			
			T93
2,16			
			T93
2,27			
			T93
2,33			
			T93
2,61			
			T93
2,70			
			T93
3,24			
			T93
3,78		51	3.58.25
		48	4.04.52
		45	4.15.31
0,00		V	T94
1,15			
			T94
1,71		36	4.00.26
		33	4.07.00
		30	4.17.48
		V	T95

DOMINGO		40/62	
2,27		447	T95
2,66		448	T95
<b>EM FRENTE ATÉ A CERCA</b>			
2,73		449	T95
2,83		450	T95
2,90		451	T95
2,92		452	T95
<b>PELO TRILHO DO GADO ATÉ A CERCA</b>			
2,97		453	T95
3,05		18 4.02.40 15 4.09.26 12 4.20.29 V T96	
3,09		455	T96
<b>DENTRO DO RIO</b>			
3,12		456	T96
<b>SAIA</b>			
3,14		27 4.02.58 24 4.09.48 21 4.20.56 V T97	





DOMINGO		41/62	
<b>BEIRANDO A MATA</b>			
3,18		458	T97
<b>PPAL</b>			
3,65		48 4.04.06 45 4.11.04 42 4.22.23 V T98	
0,00		459	
0,47		460	T98
1,00		461	T98
1,29		462	T98
1,35		463	T98
1,40		24 4.05.51 21 4.12.56 18 4.24.23 V T99	
1,43		465	T99
<b>CRUZE</b>			
1,48		466	T99
<b>BREJO</b>			
1,54		467	T99
1,61		42 4.06.22 39 4.13.32 36 4.25.05 V T100	
1,69		469	T100

DOMINGO		42/62	
2,14		48 4.07.08 45 4.14.21 42 4.25.58 V T101	
2,22		471	T101
2,63		39 4.07.44 36 4.15.01 33 4.26.40 V T102	
0,00		472	
<b>BREJO</b>			
0,17		473	T102
<b>AINDA BREJO</b>			
0,23		474	T102
0,48		475	T102
0,65		476	T102
0,81		477	T102
0,89		478	T102
1,04		479	T102
<b>CRUZE</b>			
1,07		480	T102
1,11		481	T102



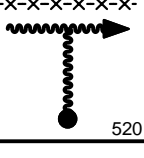

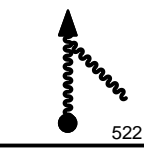
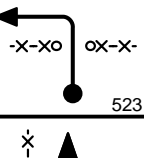

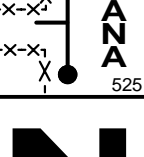
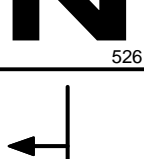
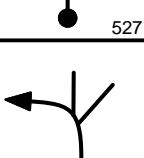
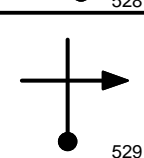
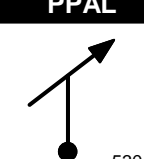
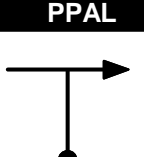
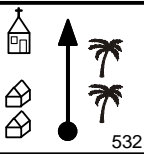
DOMINGO		43/62	
1,18		482	T102
1,20		483	T103
1,25		484	T103
1,44		485	T104
<b>Neutralizado</b>			
1,85		486	T105
1,85		487	T106
2,21		488	T106
2,77		489	T107
3,43		490	T108
3,67		491	T108
3,84		492	T108
3,95		493	T108
4,10		494	T109
0,00		494	T109

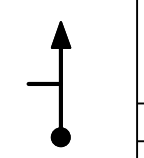
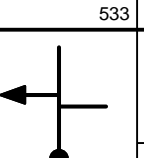
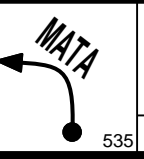
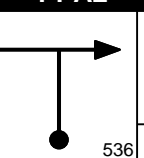
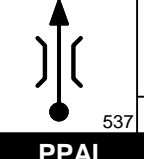
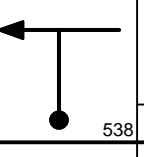
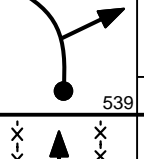
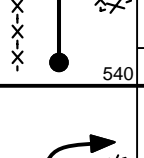
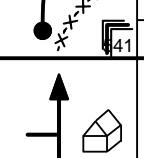
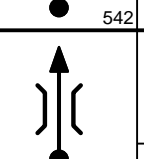
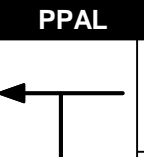
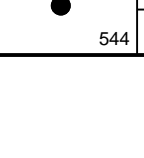
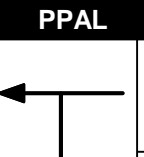
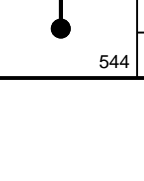
DOMINGO		44/62	
0,02		495	T109
0,14		496	T109
0,35		497	T109
<b>MANGA</b>			
0,40		498	T109
<b>P/ OS PÉS DE MANGA</b>			
0,44		499	T109
<b>PARA A MATA</b>			
0,51		500	T109
0,58		501	T110
0,68		502	T110
0,91		503	T111
1,04		504	T111
1,06		505	T111
1,12		506	T111
1,15		507	T111

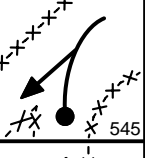
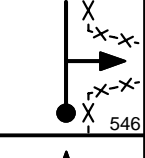
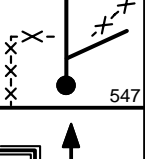
DOMINGO		45/62	
1,18		508	T111
1,28		509	T111
<b>BEIRANDO A CERCA</b>			
1,45		510	T111
1,49		511	T112
1,63		512	T112
<b>BANDEIRA</b>			
1,75		513	T112
1,78		514	T112
2,03		515	T112
2,12		516	T112
2,33		517	T112
2,38		518	T112
2,47		519	T112
<b>POR CIMA DA CURVA DE NÍVEL</b>			

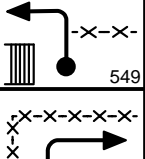
DOMINGO		46/62	
2,50		520	T112
2,60		521	T112
<b>NO TRILHO DO GADO</b>			
2,64		522	T112
2,74		523	T112
2,81		524	T112
<b>Neutralizado</b>			
3,02		525	2' 4.23.16 2' 4.31.48 2' 4.45.22 N T113
0,00	<b>N</b>	526	36 4.25.16 33 4.33.48 30 4.47.22 V T114
0,26		527	T114
0,56		528	54 4.26.12 51 4.34.49 48 4.48.29 V T115
1,69		529	T115
<b>PPAL</b>			
2,38		530	T115
<b>PPAL</b>			
2,82		531	42 4.28.43 39 4.37.28 36 4.51.19 V T116
3,71		532	T116

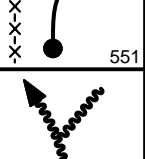
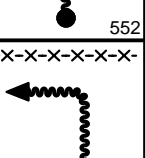
DOMINGO		47/62	
4,30		533	48 4.30.50 45 4.39.45 42 4.53.47 V T117
0,00		533	
0,49		534	T117
0,78		535	T117
<b>PPAL</b>			
1,41		536	51 4.32.35 48 4.41.38 45 4.55.48 V T118
1,65		537	T118
<b>PPAL</b>			
2,30		538	T118
2,68		539	T118
3,13		540	T118
3,64		541	27 4.35.13 24 4.44.25 21 4.58.46 V T119
4,34		542	T119
5,21		543	T119
<b>PPAL</b>			
5,28		544	54 4.38.52 51 4.48.31 48 5.03.27 V T120
0,00		544	

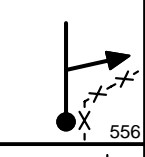
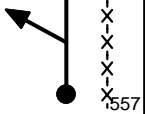
DOMINGO		48/62	
1,57		545	T120
1,88		546	27 4.40.57 24 4.50.44 21 5.05.48 V T121
1,97		547	T121
2,04		548	T121
<b>BEIRANDO A CERCA</b>			
2,06		549	T121
2,18		550	T121
<b>SUBA A ABANDONADA</b>			
2,23		551	T121
2,55		552	T121
2,59		553	T121
<b>Neutralizado</b>			
2,64		554	1' 4.42.38 1' 4.52.38 1' 5.07.58 N T122
2,64	<b>N</b>	555	48 4.43.38 45 4.53.38 42 5.08.58 V T123
2,92		556	T123
3,08		557	T123



DOMINGO		49/62	
3,16		558	T123
3,21		559	T123
3,37		560	T123
3,72		561	T123
4,06		562	T123
4,11		563	T123
4,54		45 4.46.01 42 4.56.10 39 5.11.41 V T124	
<b>0,00</b>		564	
0,09		565	T124
0,33		566	T124
<b>EROSÕES</b>			
0,41		567	T124
0,61		568	T124
<b>NA MATA</b>			
0,84		15 4.47.08 12 4.57.22 9 5.12.59 V T125	
1,02		570	T125





DOMINGO		50/62	
1,06		571	T125
1,15		572	T125
1,19		573	T125
1,27		574	T125
1,30		575	T125
1,31		576	T125
1,45		577	T125
1,48		578	T125
1,63		579	T125
1,68		580	T125
1,79		48 4.50.56 45 5.02.07 42 5.19.19 V T126	
1,92		582	T126
2,24		583	T126
2,35		584	T126



DOMINGO		51/62	
2,49		585	T126
2,61		586	T126
2,73		39 4.52.06 36 5.03.22 33 5.20.39 V T127	
<b>NO EUCALIPTO</b>			
2,79		588	T127
2,85		589	T127
2,97		590	T127
3,16		591	T127
3,47		592	T127
4,09		593	T127
4,66		594	T127
<b>Deslocamento</b>			
4,75		1' 4.55.13 1' 5.06.44 1' 5.24.20 D T128	
<b>0,00</b>		595	
<b>ABASTEÇA POR APOIO</b>			
<b>Neutralizado</b>			

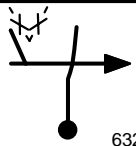
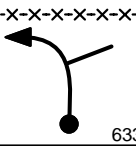
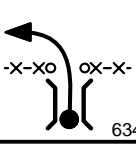
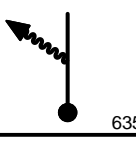
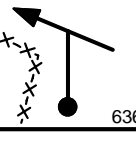
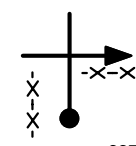

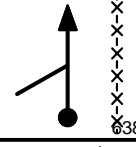
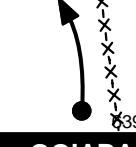
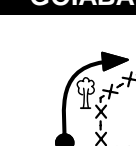
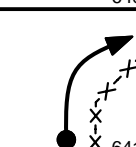
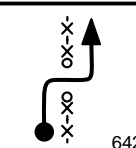

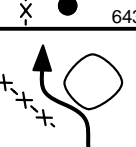
DOMINGO		52/62	
0,10		12' 4.56.13 10' 5.07.44 8' 5.25.20	N T129
<b>TOTEM</b>			
Deslocamento			
0,10	<b>N</b>	1' 5.08.13 1' 5.17.44 1' 5.33.20	D T130
0,26			T130
0,32		54 5.09.13 51 5.18.44 48 5.34.20	V T131
0,36			T131
1,51			T131
2,08			T131
3,46			T131
4,52		45 5.13.53 42 5.23.40 39 5.39.35	V T132
5,91		39 5.15.44 36 5.25.39 33 5.41.43	V T133
0,00			
0,02			T133
<b>MATA BURRO QUEBRADO</b>			

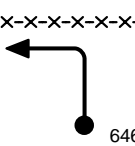
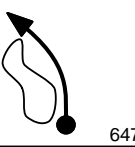
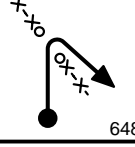
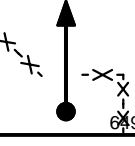
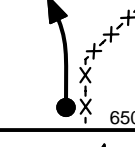
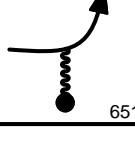
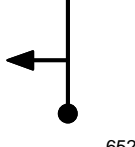

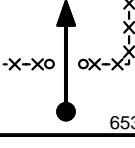
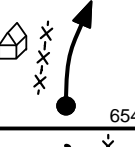
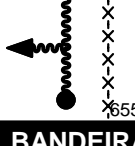

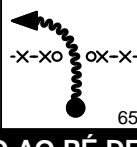
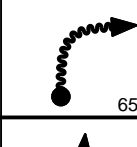
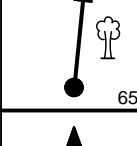

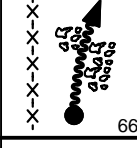
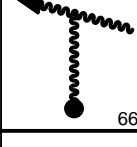
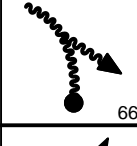
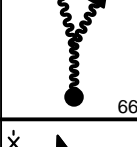

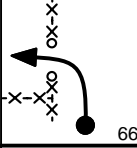
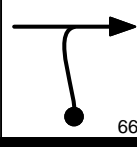
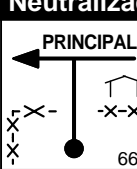

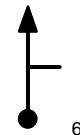

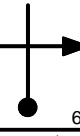
DOMINGO		53/62	
0,35			T133
0,61			T133
<b>BREJO</b>			
0,93			T133
<b>PEDRITAS</b>			
1,00			T133
<b>MANGAS</b>			
1,10			T133
<b>MATA BURRO QUEBRADO</b>			
1,40			T133
1,64			T133
2,01			T133
<b>EROSÃO</b>			
2,16			T133
2,17			T133
2,27		48 5.19.14 45 5.29.26 42 5.45.51	V T134
<b>PPAL</b>			
2,85			T134

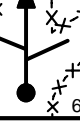

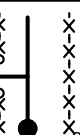



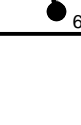

DOMINGO		54/62	
3,43		54 5.20.41 51 5.30.59 48 5.47.30	V T135
0,00			☠☠
0,77			T135
1,43			T135
2,54			T135
3,21		48 5.24.15 45 5.34.46 42 5.51.31	V T136
0,00			
0,02			T136
0,14			T136
0,78			T136
1,09		39 5.25.36 36 5.36.13 33 5.53.04	V T137
1,38		51 5.26.03 48 5.36.42 45 5.53.36	V T138
2,24			T138
2,43			T138
2,52			T138

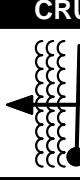
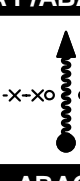

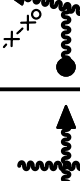





DOMINGO		55/62	
2,70			
	632	T138	
2,84			
	633	T138	
2,94			
	634	T138	
3,13			
	635	T138	
3,21			
	636	T138	
3,30		39 5.28.19 36 5.39.06 33 5.56.09	
0,00		V	T139
0,06			T139
0,17			T139
<b>GOIABA</b>			
0,31			T139
0,38			T139
0,52			T139
<b>PELA ABANDONADA</b>			
0,63			T139
0,84		27 5.29.36 24 5.40.30 21 5.57.41	
	644	V	T140

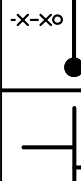

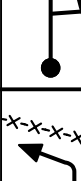

DOMINGO		56/62	
<b>BREJO, GÁZZZZ!!!!</b>			
0,85			
	645	T140	
<b>CONTINUE PELA ABANDONADA</b>			
0,88			
	646	T140	
<b>EROSÕES</b>			
0,95			
	647	T140	
1,12			
	648	T140	
1,34			
	649	T140	
1,80			
	650	T140	
1,86		42 5.31.52 39 5.43.03 36 6.00.36	
	651	V	T141
2,80		27 5.33.13 24 5.44.30 21 6.02.10	
0,00		V	T142
0,01			T142
0,23			T142
0,27		21 5.33.49 18 5.45.10 15 6.02.56	
	655	V	T143
<b>BANDEIRA</b>			

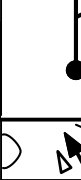
DOMINGO		57/62	
0,44			
	656	T143	
<b>RUMO AO PÉ DE MANGA</b>			
0,46			
	657	T143	
0,50			
	658	T143	
0,60			
	659	T143	
<b>PEDRITAS, BANDEIRAS</b>			
0,68			
	660	T143	
1,27			
	661	T143	
1,37			
	662	T143	
1,43			
	663	T143	
1,58			
	664	T143	
<b>PELA PRINCIPAL</b>			
1,59			
	665	T143	
1,67		45 5.37.49 42 5.49.50 39 6.08.32	
	666	V	T144
<b>Neutralizado</b>			
2,43		2' 5.38.50 2' 5.50.55 2' 6.09.42	
	667	N	T145
0,00	<b>N</b>	51 5.40.50 48 5.52.55 45 6.11.42	
	668	V	T146

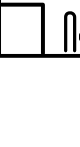
DOMINGO		58/62	
1,00		669	T146
1,71		670	T146
2,45		671	T146
2,96		672	T146
3,49		673	T146
3,92		45 5.45.26 42 5.57.49 39 6.16.56 V T147	
0,00		674	
0,70		39 5.46.22 36 5.58.49 33 6.18.01 V T148	
1,07		676	T148
1,24		677	T148
1,43		21 5.47.30 18 6.00.02 15 6.19.20 V T149	
1,58		679	T149
<b>BAMBU</b>			
1,72		680	T149
<b>NA LAJE</b>			
1,77		681	T149

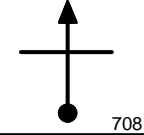
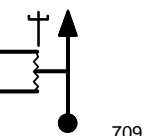
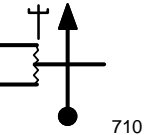
DOMINGO		59/62	
<b>CRUZE</b>			
1,79		39 5.48.31 36 6.01.14 33 6.20.47 V T150	
<b>SUBA P/ABANDONADA</b>			
1,83		683	T150
<b>ABACATE</b>			
2,06		684	T150
<b>BREJO</b>			
2,30		685	T150
2,68		686	T150
2,98		687	T150
3,23		688	T150
3,31		689	T150
3,42		690	T150
3,66		691	T150
3,69		45 5.51.27 42 6.04.24 39 6.24.14 V T151	
0,00		692	
0,01		693	T151

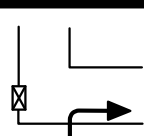
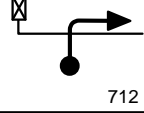
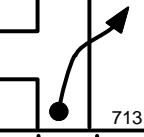
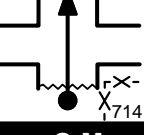
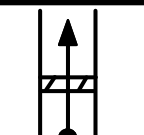
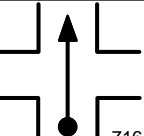
DOMINGO		60/62	
0,41		694	T151
0,90		695	T151
1,02		696	T151
1,06		697	T151
1,12		698	T151
1,57		699	T151
1,67		700	T151
1,89		701	T151
2,19		702	T151
2,58		703	T151
<b>Deslocamento</b>			
3,10		3' 5.55.35 3' 6.08.50 3' 6.29.00 D T152	
0,00		704	
0,38		705	T152
<b>DEPOIS DO MURO</b>			
0,87		45 5.58.35 42 6.11.50 39 6.32.00 V T153	

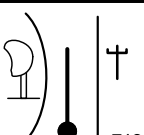
DOMINGO		61/62	
0,94			T153
1,17			T153
<b>MADEIREIRA</b>			
1,35			T153
1,49			T153
<b>EROSÃO</b>			
1,57			T153
<b>Deslocamento</b>			
1,62		5' 5.59.35 5' 6.12.54 5' 6.33.09	D T154
0,00			
0,03			T154
0,17			T154
<b>Q.M.</b>			
0,47			T154
0,83			T154
1,07			T154
<b>Neutralizado</b>			
1,19		0' 6.04.35 0' 6.17.54 0' 6.38.09	N T155

**FIM DA PROVA !!**

DOMINGO		62/62	
			
Planilha gerada pelo programa TotemPlanilha que foi criado pela Totem.			
ESTA É UMA DAS FORMAS QUE A TOTEM PARTICIPA DA EVOLUÇÃO DO OFF ROAD.			
<a href="http://WWW.TOTEMONLINE.COM.BR">WWW.TOTEMONLINE.COM.BR</a>			
Planilha_JandaiadoSul.pla			
ADCB5245B905		v5.32	
<b>ESPERAMOS QUE TENHA GOSTADO!!!</b>			
<b>OBRIGADO POR TER PARTICIPADO.</b>			